

# B

A P P E N D I X

*Imagination is more  
important than  
knowledge.*

**Albert Einstein**  
*On Science, 1930s*

## **Graphics and Computing GPUs**

*John Nickolls*  
Director of Architecture  
NVIDIA

*David Kirk*  
Chief Scientist  
NVIDIA

<b>B.1</b>	<b>Introduction</b>	B-3
<b>B.2</b>	<b>GPU System Architectures</b>	B-7
<b>B.3</b>	<b>Programming GPUs</b>	B-12
<b>B.4</b>	<b>Multithreaded Multiprocessor Architecture</b>	B-25
<b>B.5</b>	<b>Parallel Memory System</b>	B-36
<b>B.6</b>	<b>Floating-point Arithmetic</b>	B-41
<b>B.7</b>	<b>Real Stuff: The NVIDIA GeForce 8800</b>	B-46
<b>B.8</b>	<b>Real Stuff: Mapping Applications to GPUs</b>	B-55
<b>B.9</b>	<b>Fallacies and Pitfalls</b>	B-72
<b>B.10</b>	<b>Concluding Remarks</b>	B-76
<b>B.11</b>	<b>Historical Perspective and Further Reading</b>	B-77

---

## B.1 Introduction

This appendix focuses on the **GPU**—the ubiquitous **graphics processing unit** in every PC, laptop, desktop computer, and workstation. In its most basic form, the GPU generates 2D and 3D graphics, images, and video that enable Window-based operating systems, graphical user interfaces, video games, visual imaging applications, and video. The modern GPU that we describe here is a highly parallel, highly multithreaded multiprocessor optimized for **visual computing**. To provide real-time visual interaction with computed objects via graphics, images, and video, the GPU has a unified graphics and computing architecture that serves as both a programmable graphics processor and a scalable parallel computing platform. PCs and game consoles combine a GPU with a CPU to form **heterogeneous systems**.

### A Brief History of GPU Evolution

Fifteen years ago, there was no such thing as a GPU. Graphics on a PC were performed by a *video graphics array* (VGA) controller. A VGA controller was simply a memory controller and display generator connected to some DRAM. In the 1990s, semiconductor technology advanced sufficiently that more functions could be added to the VGA controller. By 1997, VGA controllers were beginning to incorporate some *three-dimensional* (3D) acceleration functions, including

**graphics processing unit (GPU)** A processor optimized for 2D and 3D graphics, video, visual computing, and display.

**visual computing** A mix of graphics processing and computing that lets you visually interact with computed objects via graphics, images, and video.

**heterogeneous system** A system combining different processor types. A PC is a heterogeneous CPU–GPU system.

hardware for triangle setup and rasterization (dicing triangles into individual pixels) and texture mapping and shading (applying “decals” or patterns to pixels and blending colors).

In 2000, the single chip graphics processor incorporated almost every detail of the traditional high-end workstation graphics pipeline and, therefore, deserved a new name beyond VGA controller. The term GPU was coined to denote that the graphics device had become a processor.

Over time, GPUs became more programmable, as programmable processors replaced fixed-function dedicated logic while maintaining the basic 3D graphics pipeline organization. In addition, computations became more precise over time, progressing from indexed arithmetic, to integer and fixed point, to single-precision floating-point, and recently to double-precision floating-point. GPUs have become massively parallel programmable processors with hundreds of cores and thousands of threads.

Recently, processor instructions and memory hardware were added to support general purpose programming languages, and a programming environment was created to allow GPUs to be programmed using familiar languages, including C and C++. This innovation makes a GPU a fully general-purpose, programmable, manycore processor, albeit still with some special benefits and limitations.

## GPU Graphics Trends

GPUs and their associated drivers implement the OpenGL and DirectX models of graphics processing. OpenGL is an open standard for 3D graphics programming available for most computers. DirectX is a series of Microsoft multimedia programming interfaces, including Direct3D for 3D graphics. Since these **application programming interfaces (APIs)** have well-defined behavior, it is possible to build effective hardware acceleration of the graphics processing functions defined by the APIs. This is one of the reasons (in addition to increasing device density) why new GPUs are being developed every 12 to 18 months that double the performance of the previous generation on existing applications.

Frequent doubling of GPU performance enables new applications that were not previously possible. The intersection of graphics processing and parallel computing invites a new paradigm for graphics, known as visual computing. It replaces large sections of the traditional sequential hardware graphics pipeline model with programmable elements for geometry, vertex, and pixel programs. Visual computing in a modern GPU combines graphics processing and parallel computing in novel ways that permit new graphics algorithms to be implemented, and opens the door to entirely new parallel processing applications on pervasive high-performance GPUs.

## Heterogeneous System

Although the GPU is arguably the most parallel and most powerful processor in a typical PC, it is certainly not the only processor. The CPU, now multicore and

**application programming interface (API)** A set of function and data structure definitions providing an interface to a library of functions.

soon to be manycore, is a complementary, primarily serial processor companion to the massively parallel manycore GPU. Together, these two types of processors comprise a heterogeneous multiprocessor system.

The best performance for many applications comes from using both the CPU and the GPU. This appendix will help you understand how and when to best split the work between these two increasingly parallel processors.

## GPU Evolves into Scalable Parallel Processor

GPUs have evolved functionally from hardwired, limited capability VGA controllers to programmable parallel processors. This evolution has proceeded by changing the logical (API-based) graphics pipeline to incorporate programmable elements and also by making the underlying hardware pipeline stages less specialized and more programmable. Eventually, it made sense to merge disparate programmable pipeline elements into one unified array of many programmable processors.

In the GeForce 8-series generation of GPUs, the geometry, vertex, and pixel processing all run on the same type of processor. This unification allows for dramatic scalability. More programmable processor cores increase the total system throughput. Unifying the processors also delivers very effective load balancing, since any processing function can use the whole processor array. At the other end of the spectrum, a processor array can now be built with very few processors, since all of the functions can be run on the same processors.

## Why CUDA and GPU Computing?

This uniform and scalable array of processors invites a new model of programming for the GPU. The large amount of floating-point processing power in the GPU processor array is very attractive for solving nongraphics problems. Given the large degree of parallelism and the range of scalability of the processor array for graphics applications, the programming model for more general computing must express the massive parallelism directly, but allow for scalable execution.

**GPU computing** is the term coined for using the GPU for computing via a parallel programming language and API, without using the traditional graphics API and graphics pipeline model. This is in contrast to the earlier **General Purpose computation on GPU (GPGPU)** approach, which involves programming the GPU using a graphics API and graphics pipeline to perform nongraphics tasks.

**Compute Unified Device Architecture (CUDA)** is a scalable parallel programming model and software platform for the GPU and other parallel processors that allows the programmer to bypass the graphics API and graphics interfaces of the GPU and simply program in C or C++. The CUDA programming model has an SPMD (single-program multiple data) software style, in which a programmer writes a program for one thread that is instanced and executed by many threads in parallel on the multiple processors of the GPU. In fact, CUDA also provides a facility for programming multiple CPU cores as well, so CUDA is an environment for writing parallel programs for the entire heterogeneous computer system.

**GPU computing** Using a GPU for computing via a parallel programming language and API.

**GPGPU** Using a GPU for general-purpose computation via a traditional graphics API and graphics pipeline.

**CUDA** A scalable parallel programming model and language based on C/C++. It is a parallel programming platform for GPUs and multicore CPUs.

## GPU Unifies Graphics and Computing

With the addition of CUDA and GPU computing to the capabilities of the GPU, it is now possible to use the GPU as both a graphics processor and a computing processor at the same time, and to combine these uses in visual computing applications. The underlying processor architecture of the GPU is exposed in two ways: first, as implementing the programmable graphics APIs, and second, as a massively parallel processor array programmable in C/C++ with CUDA.

Although the underlying processors of the GPU are unified, it is not necessary that all of the SPMD thread programs are the same. The GPU can run graphics shader programs for the graphics aspect of the GPU, processing geometry, vertices, and pixels, and also run thread programs in CUDA.

The GPU is truly a versatile multiprocessor architecture, supporting a variety of processing tasks. GPUs are excellent at graphics and visual computing as they were specifically designed for these applications. GPUs are also excellent at many general-purpose throughput applications that are “first cousins” of graphics, in that they perform a lot of parallel work, as well as having a lot of regular problem structure. In general, they are a good match to data-parallel problems (see Chapter 6), particularly large problems, but less so for less regular, smaller problems.

## GPU Visual Computing Applications

Visual computing includes the traditional types of graphics applications plus many new applications. The original purview of a GPU was “anything with pixels,” but it now includes many problems without pixels but with regular computation and/or data structure. GPUs are effective at 2D and 3D graphics, since that is the purpose for which they are designed. Failure to deliver this application performance would be fatal. 2D and 3D graphics use the GPU in its “graphics mode,” accessing the processing power of the GPU through the graphics APIs, OpenGL™, and DirectX™. Games are built on the 3D graphics processing capability.

Beyond 2D and 3D graphics, image processing and video are important applications for GPUs. These can be implemented using the graphics APIs or as computational programs, using CUDA to program the GPU in computing mode. Using CUDA, image processing is simply another data-parallel array program. To the extent that the data access is regular and there is good locality, the program will be efficient. In practice, image processing is a very good application for GPUs. Video processing, especially encode and decode (compression and decompression according to some standard algorithms), is quite efficient.

The greatest opportunity for visual computing applications on GPUs is to “break the graphics pipeline.” Early GPUs implemented only specific graphics APIs, albeit at very high performance. This was wonderful if the API supported the operations that you wanted to do. If not, the GPU could not accelerate your task, because early GPU functionality was immutable. Now, with the advent of GPU computing and CUDA, these GPUs can be programmed to implement a different virtual pipeline by simply writing a CUDA program to describe the computation and data flow that is desired. So, all applications are now possible, which will stimulate new visual computing approaches.

## B.2 GPU System Architectures

In this section, we survey GPU system architectures in common use today. We discuss system configurations, GPU functions and services, standard programming interfaces, and a basic GPU internal architecture.

### Heterogeneous CPU–GPU System Architecture

A heterogeneous computer system architecture using a GPU and a CPU can be described at a high level by two primary characteristics: first, how many functional subsystems and/or chips are used and what are their interconnection technologies and topology; and second, what memory subsystems are available to these functional subsystems. See Chapter 6 for background on the PC I/O systems and chip sets.

#### The Historical PC (circa 1990)

Figure B.2.1 shows a high-level block diagram of a legacy PC, circa 1990. The north bridge (see Chapter 6) contains high-bandwidth interfaces, connecting the CPU, memory, and PCI bus. The south bridge contains legacy interfaces and devices: ISA bus (audio, LAN), interrupt controller; DMA controller; time/counter. In this system, the display was driven by a simple framebuffer subsystem known

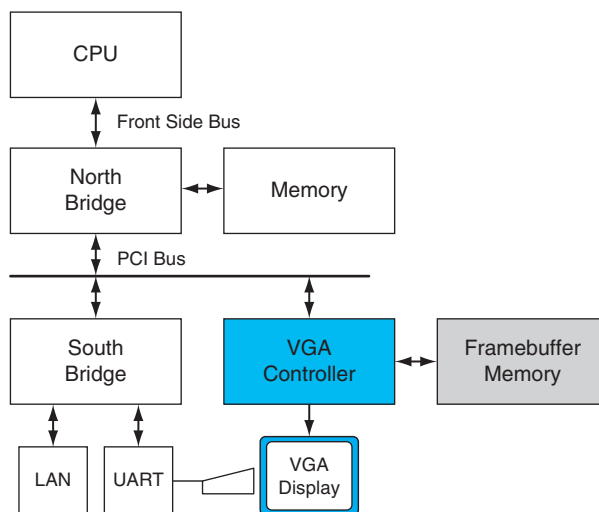

**FIGURE B.2.1 Historical PC.** VGA controller drives graphics display from framebuffer memory.

**PCI-Express (PCIe)**

A standard system I/O interconnect that uses point-to-point links. Links have a configurable number of lanes and bandwidth.

as a VGA (*video graphics array*) which was attached to the PCI bus. Graphics subsystems with built-in processing elements (GPUs) did not exist in the PC landscape of 1990.

Figure B.2.2 illustrates two configurations in common use today. These are characterized by a separate GPU (discrete GPU) and CPU with respective memory subsystems. In Figure B.2.2a, with an Intel CPU, we see the GPU attached via a 16-lane **PCI-Express** 2.0 link to provide a peak 16 GB/s transfer rate (peak of 8 GB/s in each direction). Similarly, in Figure B.2.2b, with an AMD CPU, the GPU

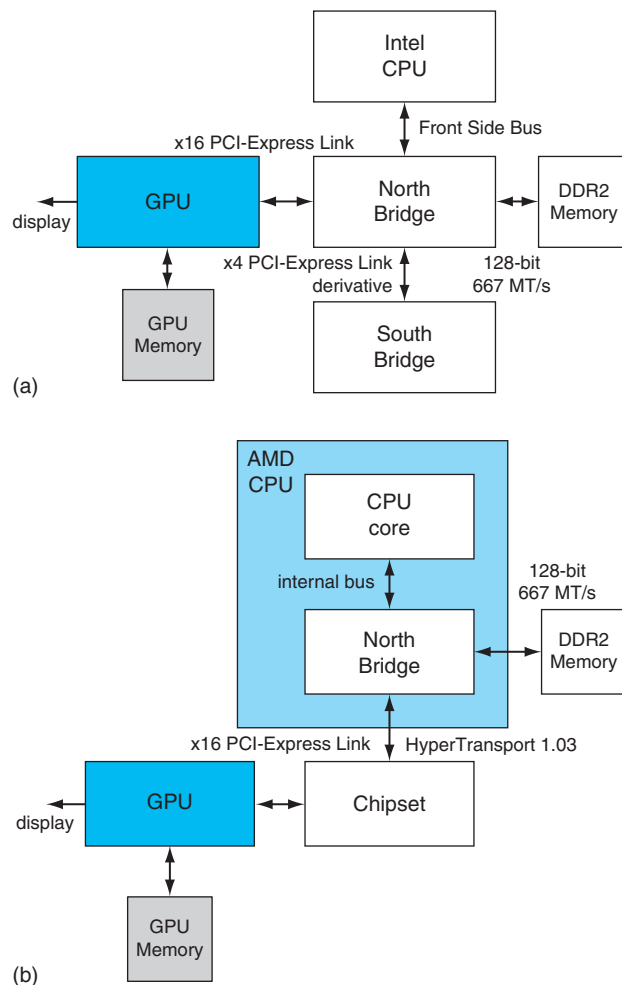

**FIGURE B.2.2 Contemporary PCs with Intel and AMD CPUs.** See Chapter 6 for an explanation of the components and interconnects in this figure.

is attached to the chipset, also via PCI-Express with the same available bandwidth. In both cases, the GPUs and CPUs may access each other's memory, albeit with less available bandwidth than their access to the more directly attached memories. In the case of the AMD system, the north bridge or memory controller is integrated into the same die as the CPU.

A low-cost variation on these systems, a **unified memory architecture (UMA)** system, uses only CPU system memory, omitting GPU memory from the system. These systems have relatively low-performance GPUs, since their achieved performance is limited by the available system memory bandwidth and increased latency of memory access, whereas dedicated GPU memory provides high bandwidth and low latency.

A high-performance system variation uses multiple attached GPUs, typically two to four working in parallel, with their displays daisy-chained. An example is the NVIDIA SLI (scalable link interconnect) multi-GPU system, designed for high-performance gaming and workstations.

The next system category integrates the GPU with the north bridge (Intel) or chipset (AMD) with and without dedicated graphics memory.

Chapter 5 explains how caches maintain coherence in a shared address space. With CPUs and GPUs, there are multiple address spaces. GPUs can access their own physical local memory and the CPU system's physical memory using virtual addresses that are translated by an MMU on the GPU. The operating system kernel manages the GPU's page tables. A system physical page can be accessed using either coherent or noncoherent PCI-Express transactions, determined by an attribute in the GPU's page table. The CPU can access GPU's local memory through an address range (also called aperture) in the PCI-Express address space.

## Game Consoles

Console systems such as the Sony PlayStation 3 and the Microsoft Xbox 360 resemble the PC system architectures previously described. Console systems are designed to be shipped with identical performance and functionality over a lifespan that can last five years or more. During this time, a system may be reimplemented many times to exploit more advanced silicon manufacturing processes and thereby to provide constant capability at ever lower costs. Console systems do not need to have their subsystems expanded and upgraded the way PC systems do, so the major internal system buses tend to be customized rather than standardized.

## GPU Interfaces and Drivers

In a PC today, GPUs are attached to a CPU via PCI-Express. Earlier generations used **AGP**. Graphics applications call OpenGL [Segal and Akeley, 2006] or Direct3D [Microsoft DirectX Specification] API functions that use the GPU as a coprocessor. The APIs send commands, programs, and data to the GPU via a graphics device driver optimized for the particular GPU.

### unified memory architecture (UMA)

A system architecture in which the CPU and GPU share a common system memory.

**AGP** An extended version of the original PCI I/O bus, which provided up to eight times the bandwidth of the original PCI bus to a single card slot. Its primary purpose was to connect graphics subsystems into PC systems.



## Graphics Logical Pipeline

The graphics logical pipeline is described in Section B.3. Figure B.2.3 illustrates the major processing stages, and highlights the important programmable stages (vertex, geometry, and pixel shader stages).



**FIGURE B.2.3 Graphics logical pipeline.** Programmable graphics shader stages are blue, and fixed-function blocks are white.

## Mapping Graphics Pipeline to Unified GPU Processors

Figure B.2.4 shows how the logical pipeline comprising separate independent programmable stages is mapped onto a physical distributed array of processors.

### Basic Unified GPU Architecture

Unified GPU architectures are based on a parallel array of many programmable processors. They unify vertex, geometry, and pixel shader processing and parallel computing on the same processors, unlike earlier GPUs which had separate processors dedicated to each processing type. The programmable processor array is tightly integrated with fixed function processors for texture filtering, rasterization, raster operations, anti-aliasing, compression, decompression, display, video decoding, and high-definition video processing. Although the fixed-function processors significantly outperform more general programmable processors in terms of absolute performance constrained by an area, cost, or power budget, we will focus on the programmable processors here.

Compared with multicore CPUs, manycore GPUs have a different architectural design point, one focused on executing many parallel threads efficiently on many

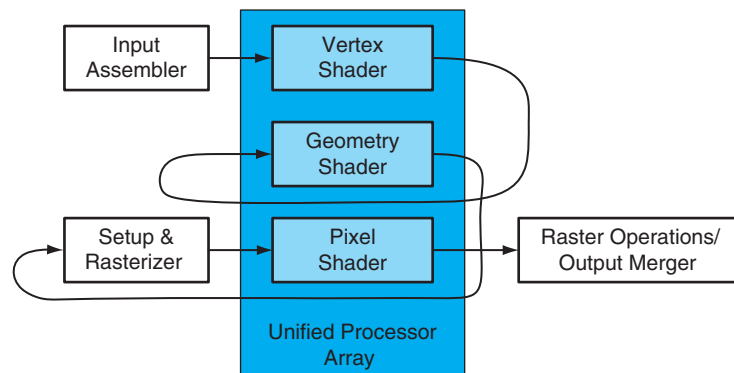
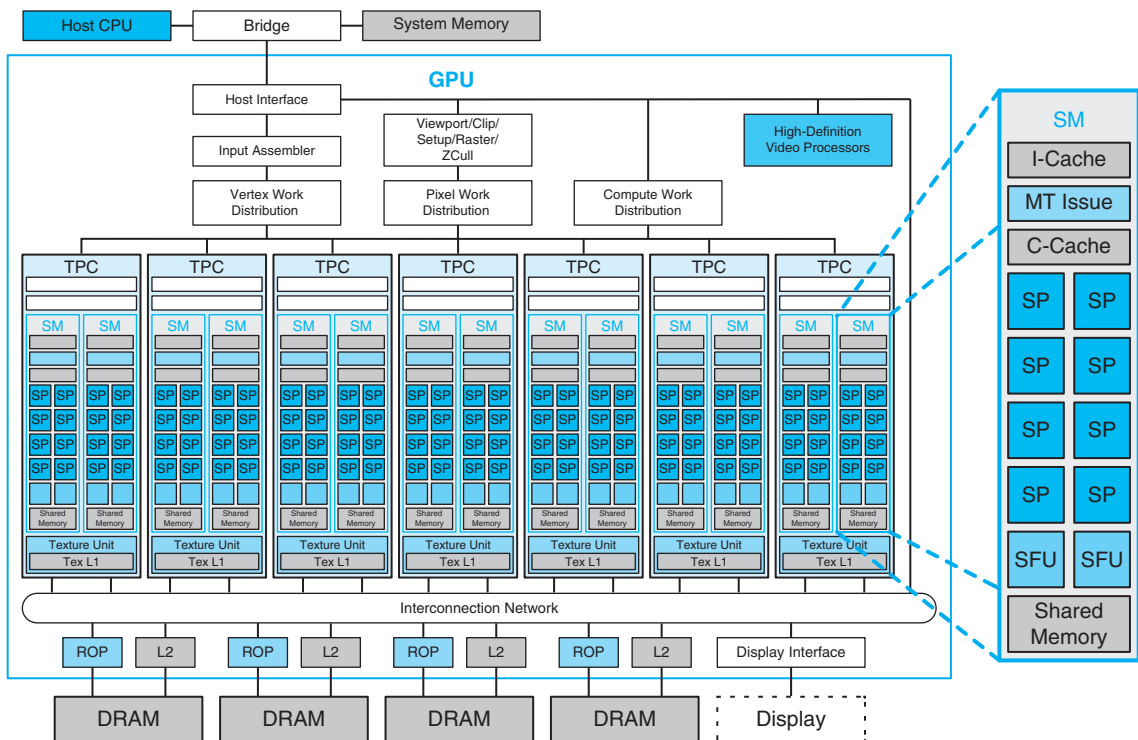

**FIGURE B.2.4 Logical pipeline mapped to physical processors.** The programmable shader stages execute on the array of unified processors, and the logical graphics pipeline dataflow recirculates through the processors.

processor cores. By using many simpler cores and optimizing for data-parallel behavior among groups of threads, more of the per-chip transistor budget is devoted to computation, and less to on-chip caches and overhead.

### Processor Array

A unified GPU processor array contains many processor cores, typically organized into multithreaded multiprocessors. Figure B.2.5 shows a GPU with an array of 112 *streaming processor* (SP) cores, organized as 14 multithreaded *streaming multiprocessors* (SMs). Each SP core is highly multithreaded, managing 96 concurrent threads and their state in hardware. The processors connect with four 64-bit-wide DRAM partitions via an interconnection network. Each SM has eight SP cores, two *special function units* (SFUs), instruction and constant caches, a multithreaded instruction unit, and a shared memory. This is the basic Tesla architecture implemented by the NVIDIA GeForce 8800. It has a unified architecture in which the traditional graphics programs for vertex, geometry, and pixel shading run on the unified SMs and their SP cores, and computing programs run on the same processors.



**FIGURE B.2.5 Basic unified GPU architecture.** Example GPU with 112 *streaming processor* (SP) cores organized in 14 *streaming multiprocessors* (SMs); the cores are highly multithreaded. It has the basic Tesla architecture of an NVIDIA GeForce 8800. The processors connect with four 64-bit-wide DRAM partitions via an interconnection network. Each SM has eight SP cores, two *special function units* (SFUs), instruction and constant caches, a multithreaded instruction unit, and a shared memory.

The processor array architecture is scalable to smaller and larger GPU configurations by scaling the number of multiprocessors and the number of memory partitions. Figure B.2.5 shows seven clusters of two SMs sharing a texture unit and a texture L1 cache. The texture unit delivers filtered results to the SM given a set of coordinates into a texture map. Because filter regions of support often overlap for successive texture requests, a small streaming L1 texture cache is effective to reduce the number of requests to the memory system. The processor array connects with *raster operation processors* (ROPs), L2 texture caches, external DRAM memories, and system memory via a GPU-wide interconnection network. The number of processors and number of memories can scale to design balanced GPU systems for different performance and market segments.

## **B.3** Programming GPUs

Programming multiprocessor GPUs is qualitatively different than programming other multiprocessors like multicore CPUs. GPUs provide two to three orders of magnitude more thread and data parallelism than CPUs, scaling to hundreds of processor cores and tens of thousands of concurrent threads. GPUs continue to increase their parallelism, doubling it about every 12 to 18 months, enabled by Moore's law [1965] of increasing integrated circuit density and by improving architectural efficiency. To span the wide price and performance range of different market segments, different GPU products implement widely varying numbers of processors and threads. Yet users expect games, graphics, imaging, and computing applications to work on any GPU, regardless of how many parallel threads it executes or how many parallel processor cores it has, and they expect more expensive GPUs (with more threads and cores) to run applications faster. As a result, GPU programming models and application programs are designed to scale transparently to a wide range of parallelism.

The driving force behind the large number of parallel threads and cores in a GPU is real-time graphics performance—the need to render complex 3D scenes with high resolution at interactive frame rates, at least 60 frames per second. Correspondingly, the scalable programming models of graphics shading languages such as Cg (C for graphics) and HLSL (*high-level shading language*) are designed to exploit large degrees of parallelism via many independent parallel threads and to scale to any number of processor cores. The CUDA scalable parallel programming model similarly enables general parallel computing applications to leverage large numbers of parallel threads and scale to any number of parallel processor cores, transparently to the application.

In these scalable programming models, the programmer writes code for a single thread, and the GPU runs myriad thread instances in parallel. Programs thus scale transparently over a wide range of hardware parallelism. This simple paradigm arose from graphics APIs and shading languages that describe how to shade one

vertex or one pixel. It has remained an effective paradigm as GPUs have rapidly increased their parallelism and performance since the late 1990s.

This section briefly describes programming GPUs for real-time graphics applications using graphics APIs and programming languages. It then describes programming GPUs for visual computing and general parallel computing applications using the C language and the CUDA programming model.

## Programming Real-Time Graphics

APIs have played an important role in the rapid, successful development of GPUs and processors. There are two primary standard graphics APIs: **OpenGL** and **Direct3D**, one of the Microsoft DirectX multimedia programming interfaces. OpenGL, an open standard, was originally proposed and defined by Silicon Graphics Incorporated. The ongoing development and extension of the OpenGL standard [Segal and Akeley, 2006; Kessenich, 2006] is managed by Khronos, an industry consortium. Direct3D [Blythe, 2006], a de facto standard, is defined and evolved forward by Microsoft and partners. OpenGL and Direct3D are similarly structured, and continue to evolve rapidly with GPU hardware advances. They define a logical graphics processing pipeline that is mapped onto the GPU hardware and processors, along with programming models and languages for the programmable pipeline stages.

**OpenGL** An open-standard graphics API.

**Direct3D** A graphics API defined by Microsoft and partners.

## Logical Graphics Pipeline

Figure B.3.1 illustrates the Direct3D 10 logical graphics pipeline. OpenGL has a similar graphics pipeline structure. The API and logical pipeline provide a streaming dataflow infrastructure and plumbing for the programmable shader stages, shown in blue. The 3D application sends the GPU a sequence of vertices grouped into geometric primitives—points, lines, triangles, and polygons. The input assembler collects vertices and primitives. The vertex shader program executes per-vertex processing,

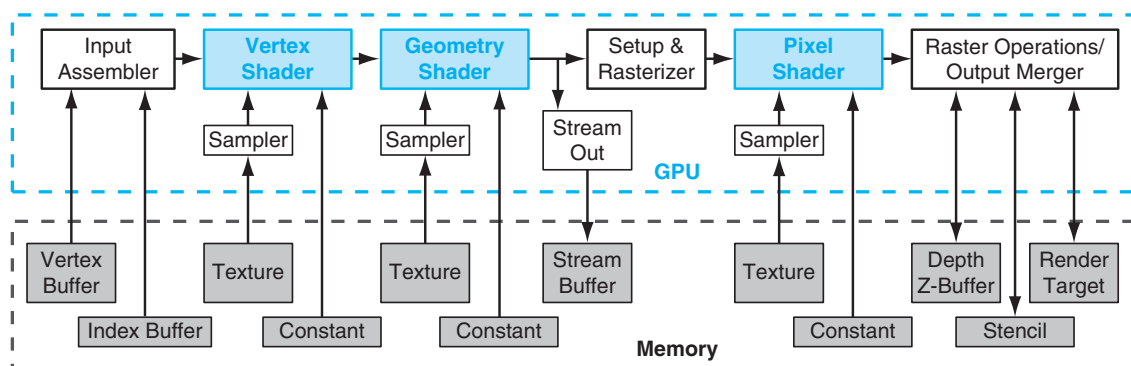

**FIGURE B.3.1 Direct3D 10 graphics pipeline.** Each logical pipeline stage maps to GPU hardware or to a GPU processor. Programmable shader stages are blue, fixed-function blocks are white, and memory objects are gray. Each stage processes a vertex, geometric primitive, or pixel in a streaming dataflow fashion.

**texture** A 1D, 2D, or 3D array that supports sampled and filtered lookups with interpolated coordinates.

including transforming the vertex 3D position into a screen position and lighting the vertex to determine its color. The geometry shader program executes per-primitive processing and can add or drop primitives. The setup and rasterizer unit generates pixel fragments (fragments are potential contributions to pixels) that are covered by a geometric primitive. The pixel shader program performs per-fragment processing, including interpolating per-fragment parameters, texturing, and coloring. Pixel shaders make extensive use of sampled and filtered lookups into large 1D, 2D, or 3D arrays called **textures**, using interpolated floating-point coordinates. Shaders use texture accesses for maps, functions, decals, images, and data. The raster operations processing (or output merger) stage performs Z-buffer depth testing and stencil testing, which may discard a hidden pixel fragment or replace the pixel's depth with the fragment's depth, and performs a color blending operation that combines the fragment color with the pixel color and writes the pixel with the blended color.

The graphics API and graphics pipeline provide input, output, memory objects, and infrastructure for the shader programs that process each vertex, primitive, and pixel fragment.

## Graphics Shader Programs

**shader** A program that operates on graphics data such as a vertex or a pixel fragment.

**shading language** A graphics rendering language, usually having a dataflow or streaming programming model.

Real-time graphics applications use many different **shader** programs to model how light interacts with different materials and to render complex lighting and shadows. **Shading languages** are based on a dataflow or streaming programming model that corresponds with the logical graphics pipeline. Vertex shader programs map the position of triangle vertices onto the screen, altering their position, color, or orientation. Typically a vertex shader thread inputs a floating-point  $(x, y, z, w)$  vertex position and computes a floating-point  $(x, y, z)$  screen position. Geometry shader programs operate on geometric primitives (such as lines and triangles) defined by multiple vertices, changing them or generating additional primitives. Pixel fragment shaders each “shade” one pixel, computing a floating-point *red, green, blue, alpha* (RGBA) color contribution to the rendered image at its pixel sample  $(x, y)$  image position. Shaders (and GPUs) use floating-point arithmetic for all pixel color calculations to eliminate visible artifacts while computing the extreme range of pixel contribution values encountered while rendering scenes with complex lighting, shadows, and high dynamic range. For all three types of graphics shaders, many program instances can be run in parallel, as independent parallel threads, because each works on independent data, produces independent results, and has no side effects. Independent vertices, primitives, and pixels further enable the same graphics program to run on differently sized GPUs that process different numbers of vertices, primitives, and pixels in parallel. Graphics programs thus scale transparently to GPUs with different amounts of parallelism and performance.

Users program all three logical graphics threads with a common targeted high-level language. HLSL (high-level shading language) and Cg (C for graphics) are commonly used. They have C-like syntax and a rich set of library functions for matrix operations, trigonometry, interpolation, and texture access and filtering, but are far from general computing languages: they currently lack general memory

access, pointers, file I/O, and recursion. HLSL and Cg assume that programs live within a logical graphics pipeline, and thus I/O is implicit. For example, a pixel fragment shader may expect the geometric normal and multiple texture coordinates to have been interpolated from vertex values by upstream fixed-function stages and can simply assign a value to the COLOR output parameter to pass it downstream to be blended with a pixel at an implied (x, y) position.

The GPU hardware creates a new independent thread to execute a vertex, geometry, or pixel shader program for every vertex, every primitive, and every pixel fragment. In video games, the bulk of threads execute pixel shader programs, as there are typically 10 to 20 times more pixel fragments than vertices, and complex lighting and shadows require even larger ratios of pixel to vertex shader threads. The graphics shader programming model drove the GPU architecture to efficiently execute thousands of independent fine-grained threads on many parallel processor cores.

### Pixel Shader Example

Consider the following Cg pixel shader program that implements the “environment mapping” rendering technique. For each pixel thread, this shader is passed five parameters, including 2D floating-point texture image coordinates needed to sample the surface color, and a 3D floating-point vector giving the reflection of the view direction off the surface. The other three “uniform” parameters do not vary from one pixel instance (thread) to the next. The shader looks up color in two texture images: a 2D texture access for the surface color, and a 3D texture access into a cube map (six images corresponding to the faces of a cube) to obtain the external world color corresponding to the reflection direction. Then the final four-component (red, green, blue, alpha) floating-point color is computed using a weighted average called a “lerp” or linear interpolation function.

```
void refection(
    float2          texCoord      : TEXCOORD0,
    float3          refection_dir : TEXCOORD1,
    out float4      color         : COLOR,
    uniform float   shiny,
    uniform sampler2D surfaceMap,
    uniform samplerCUBE envMap)
{
    // Fetch the surface color from a texture
    float4 surfaceColor = tex2D(surfaceMap, texCoord);

    // Fetch reflected color by sampling a cube map
    float4 reflectedColor = texCUBE(environmentMap, refection_dir);

    // Output is weighted average of the two colors
    color = lerp(surfaceColor, reflectedColor, shiny);
}
```

Although this shader program is only three lines long, it activates a lot of GPU hardware. For each texture fetch, the GPU texture subsystem makes multiple memory accesses to sample image colors in the vicinity of the sampling coordinates, and then interpolates the final result with floating-point filtering arithmetic. The multithreaded GPU executes thousands of these lightweight Cg pixel shader threads in parallel, deeply interleaving them to hide texture fetch and memory latency.

Cg focuses the programmer's view to a single vertex or primitive or pixel, which the GPU implements as a single thread; the shader program transparently scales to exploit thread parallelism on the available processors. Being application-specific, Cg provides a rich set of useful data types, library functions, and language constructs to express diverse rendering techniques.

Figure B.3.2 shows skin rendered by a fragment pixel shader. Real skin appears quite different from flesh-color paint because light bounces around a lot before re-emerging. In this complex shader, three separate skin layers, each with unique subsurface scattering behavior, are modeled to give the skin a visual depth and translucency. Scattering can be modeled by a blurring convolution in a fattened "texture" space, with red being blurred more than green, and blue blurred less. The compiled Cg shader executes 1400 instructions to compute the color of one skin pixel.



---

**FIGURE B.3.2 GPU-rendered image.** To give the skin visual depth and translucency, the pixel shader program models three separate skin layers, each with unique subsurface scattering behavior. It executes 1400 instructions to render the red, green, blue, and alpha color components of each skin pixel fragment.



As GPUs have evolved superior floating-point performance and very high streaming memory bandwidth for real-time graphics, they have attracted highly parallel applications beyond traditional graphics. At first, access to this power was available only by couching an application as a graphics-rendering algorithm, but this GPGPU approach was often awkward and limiting. More recently, the CUDA programming model has provided a far easier way to exploit the scalable high-performance floating-point and memory bandwidth of GPUs with the C programming language.

### Programming Parallel Computing Applications

CUDA, Brook, and CAL are programming interfaces for GPUs that are focused on data parallel computation rather than on graphics. CAL (*Compute Abstraction Layer*) is a low-level assembler language interface for AMD GPUs. Brook is a streaming language adapted for GPUs by Buck et al. [2004]. CUDA, developed by NVIDIA [2007], is an extension to the C and C++ languages for scalable parallel programming of manycore GPUs and multicore CPUs. The CUDA programming model is described below, adapted from an article by Nickolls et al. [2008].

With the new model the GPU excels in data parallel and throughput computing, executing high-performance computing applications as well as graphics applications.

#### Data Parallel Problem Decomposition

To map large computing problems effectively to a highly parallel processing architecture, the programmer or compiler decomposes the problem into many small problems that can be solved in parallel. For example, the programmer partitions a large result data array into blocks and further partitions each block into elements, such that the result blocks can be computed independently in parallel, and the elements within each block are computed in parallel. Figure B.3.3 shows a decomposition of a result data array into a  $3 \times 2$  grid of blocks, where each block is further decomposed into a  $5 \times 3$  array of elements. The two-level parallel decomposition maps naturally to the GPU architecture: parallel multiprocessors compute result blocks, and parallel threads compute result elements.

The programmer writes a program that computes a sequence of result data grids, partitioning each result grid into coarse-grained result blocks that can be computed independently in parallel. The program computes each result block with an array of fine-grained parallel threads, partitioning the work among threads so that each computes one or more result elements.

### Scalable Parallel Programming with CUDA

The CUDA scalable parallel programming model extends the C and C++ languages to exploit large degrees of parallelism for general applications on highly parallel multiprocessors, particularly GPUs. Early experience with CUDA shows that *many* sophisticated programs can be readily expressed with a few easily understood abstractions. Since NVIDIA released CUDA in 2007, developers have



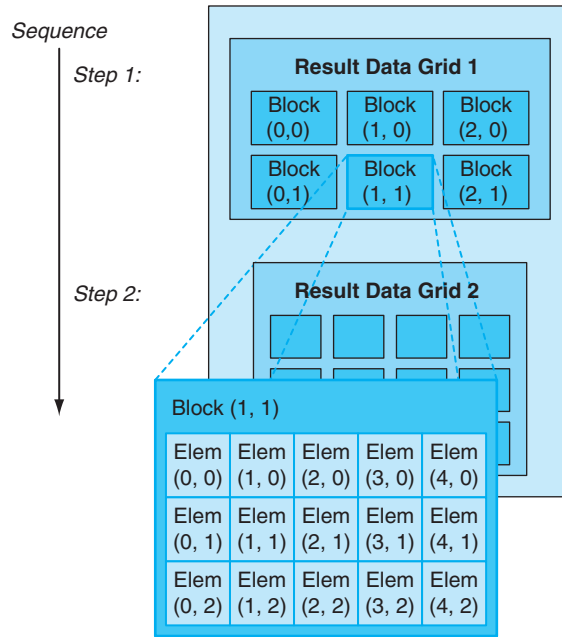

**FIGURE B.3.3** Decomposing result data into a grid of blocks of elements to be computed in parallel.

rapidly developed scalable parallel programs for a wide range of applications, including seismic data processing, computational chemistry, linear algebra, sparse matrix solvers, sorting, searching, physics models, and visual computing. These applications scale transparently to hundreds of processor cores and thousands of concurrent threads. NVIDIA GPUs with the Tesla unified graphics and computing architecture (described in Sections B.4 and B.7) run CUDA C programs, and are widely available in laptops, PCs, workstations, and servers. The CUDA model is also applicable to other shared memory parallel processing architectures, including multicore CPUs.

CUDA provides three key abstractions—a *hierarchy of thread groups*, *shared memories*, and *barrier synchronization*—that provide a clear parallel structure to conventional C code for one thread of the hierarchy. Multiple levels of threads, memory, and synchronization provide fine-grained data parallelism and thread parallelism, nested within coarse-grained data parallelism and task parallelism. The abstractions guide the programmer to partition the problem into coarse subproblems that can be solved independently in parallel, and then into finer pieces that can be solved in parallel. The programming model scales transparently to large numbers of processor cores: a compiled CUDA program executes on any number of processors, and only the runtime system needs to know the physical processor count.

## The CUDA Paradigm

CUDA is a minimal extension of the C and C++ programming languages. The programmer writes a serial program that calls parallel **kernels**, which may be simple functions or full programs. A kernel executes in parallel across a set of parallel threads. The programmer organizes these threads into a hierarchy of thread blocks and grids of thread blocks. A **thread block** is a set of concurrent threads that can cooperate among themselves through barrier synchronization and through shared access to a memory space private to the block. A **grid** is a set of thread blocks that may each be executed independently and thus may execute in parallel.

When invoking a kernel, the programmer specifies the number of threads per block and the number of blocks comprising the grid. Each thread is given a unique *thread ID* number `threadIdx` within its thread block, numbered `0, 1, 2, ..., blockDim-1`, and each thread block is given a unique *block ID* number `blockIdx` within its grid. CUDA supports thread blocks containing up to 512 threads. For convenience, thread blocks and grids may have one, two, or three dimensions, accessed via `.x`, `.y`, and `.z` index fields.

As a very simple example of parallel programming, suppose that we are given two vectors  $x$  and  $y$  of  $n$  floating-point numbers each and that we wish to compute the result of  $y = ax + y$  for some scalar value  $a$ . This is the so-called SAXPY kernel defined by the BLAS linear algebra library. Figure B.3.4 shows C code for performing this computation on both a serial processor and in parallel using CUDA.

The `__global__` declaration specifier indicates that the procedure is a kernel entry point. CUDA programs launch parallel kernels with the extended function call syntax:

```
kernel<<<dimGrid, dimBlock>>>(... parameter list ...);
```

where `dimGrid` and `dimBlock` are three-element vectors of type `dim3` that specify the dimensions of the grid in blocks and the dimensions of the blocks in threads, respectively. Unspecified dimensions default to one.

In Figure B.3.4, we launch a grid of  $n$  threads that assigns one thread to each element of the vectors and puts 256 threads in each block. Each individual thread computes an element index from its thread and block IDs and then performs the desired calculation on the corresponding vector elements. Comparing the serial and parallel versions of this code, we see that they are strikingly similar. This represents a fairly common pattern. The serial code consists of a loop where each iteration is independent of all the others. Such loops can be mechanically transformed into parallel kernels: each loop iteration becomes an independent thread. By assigning a single thread to each output element, we avoid the need for any synchronization among threads when writing results to memory.

The text of a CUDA kernel is simply a C function for one sequential thread. Thus, it is generally straightforward to write and is typically simpler than writing parallel code for vector operations. Parallelism is determined clearly and explicitly by specifying the dimensions of a grid and its thread blocks when launching a kernel.

**kernel** A program or function for one thread, designed to be executed by many threads.

**thread block** A set of concurrent threads that execute the same thread program and may cooperate to compute a result.

**grid** A set of thread blocks that execute the same kernel program.

**Computing  $y = ax + y$  with a serial loop:**

```
void saxpy_serial(int n, float alpha, float *x, float *y)
{
    for(int i = 0; i<n; ++i)
        y[i] = alpha*x[i] + y[i];
}
// Invoke serial SAXPY kernel
saxpy_serial(n, 2.0, x, y);
```

**Computing  $y = ax + y$  in parallel using CUDA:**

```
__global__
void saxpy_parallel(int n, float alpha, float *x, float *y)
{
    int i = blockIdx.x*blockDim.x + threadIdx.x;

    if( i<n ) y[i] = alpha*x[i] + y[i];
}

// Invoke parallel SAXPY kernel (256 threads per block)
int nblocks = (n + 255) / 256;
saxpy_parallel<<<nblocks, 256>>>(n, 2.0, x, y);
```

**FIGURE B.3.4 Sequential code (top) in C versus parallel code (bottom) in CUDA for SAXPY (see Chapter 6).** CUDA parallel threads replace the C serial loop—each thread computes the same result as one loop iteration. The parallel code computes  $n$  results with  $n$  threads organized in blocks of 256 threads.

Parallel execution and thread management is automatic. All thread creation, scheduling, and termination is handled for the programmer by the underlying system. Indeed, a Tesla architecture GPU performs all thread management directly in hardware. The threads of a block execute concurrently and may synchronize at a **synchronization barrier** by calling the `__syncthreads()` intrinsic. This guarantees that no thread in the block can proceed until all threads in the block have reached the barrier. After passing the barrier, these threads are also guaranteed to see all writes to memory performed by threads in the block before the barrier. Thus, threads in a block may communicate with each other by writing and reading per-block shared memory at a synchronization barrier.

Since threads in a block may share memory and synchronize via barriers, they will reside together on the same physical processor or multiprocessor. The number of thread blocks can, however, greatly exceed the number of processors. The CUDA thread programming model virtualizes the processors and gives the programmer the flexibility to parallelize at whatever granularity is most convenient. Virtualization

**synchronization**

**barrier** Threads wait at a synchronization barrier until all threads in the thread block arrive at the barrier.

into threads and thread blocks allows intuitive problem decompositions, as the number of blocks can be dictated by the size of the data being processed rather than by the number of processors in the system. It also allows the same CUDA program to scale to widely varying numbers of processor cores.

To manage this processing element virtualization and provide scalability, CUDA requires that thread blocks be able to execute independently. It must be possible to execute blocks in any order, in parallel or in series. Different blocks have no means of direct communication, although they may *coordinate* their activities using **atomic memory operations** on the global memory visible to all threads—by atomically incrementing queue pointers, for example. This independence requirement allows thread blocks to be scheduled in any order across any number of cores, making the CUDA model scalable across an arbitrary number of cores as well as across a variety of parallel architectures. It also helps to avoid the possibility of deadlock. An application may execute multiple grids either independently or dependently. Independent grids may execute concurrently, given sufficient hardware resources. Dependent grids execute sequentially, with an implicit interkernel barrier between them, thus guaranteeing that all blocks of the first grid complete before any block of the second, dependent grid begins.

Threads may access data from multiple memory spaces during their execution. Each thread has a private **local memory**. CUDA uses local memory for thread-private variables that do not fit in the thread's registers, as well as for stack frames and register spilling. Each thread block has a **shared memory**, visible to all threads of the block, which has the same lifetime as the block. Finally, all threads have access to the same **global memory**. Programs declare variables in shared and global memory with the `__shared__` and `__device__` type qualifiers. On a Tesla architecture GPU, these memory spaces correspond to physically separate memories: per-block shared memory is a low-latency on-chip RAM, while global memory resides in the fast DRAM on the graphics board.

Shared memory is expected to be a low-latency memory near each processor, much like an L1 cache. It can therefore provide high-performance communication and data sharing among the threads of a thread block. Since it has the same lifetime as its corresponding thread block, kernel code will typically initialize data in shared variables, compute using shared variables, and copy shared memory results to global memory. Thread blocks of sequentially dependent grids communicate via global memory, using it to read input and write results.

Figure B.3.5 shows diagrams of the nested levels of threads, thread blocks, and grids of thread blocks. It further shows the corresponding levels of memory sharing: local, shared, and global memories for per-thread, per-thread-block, and per-application data sharing.

A program manages the global memory space visible to kernels through calls to the CUDA runtime, such as `cudaMalloc()` and `cudaFree()`. Kernels may execute on a physically separate device, as is the case when running kernels on the GPU. Consequently, the application must use `cudaMemcpy()` to copy data between the allocated space and the host system memory.

#### atomic memory operation

A memory read, modify, write operation sequence that completes without any intervening access.

**local memory** Per-thread local memory private to the thread.

**shared memory** Per-block memory shared by all threads of the block.

**global memory** Per-application memory shared by all threads.

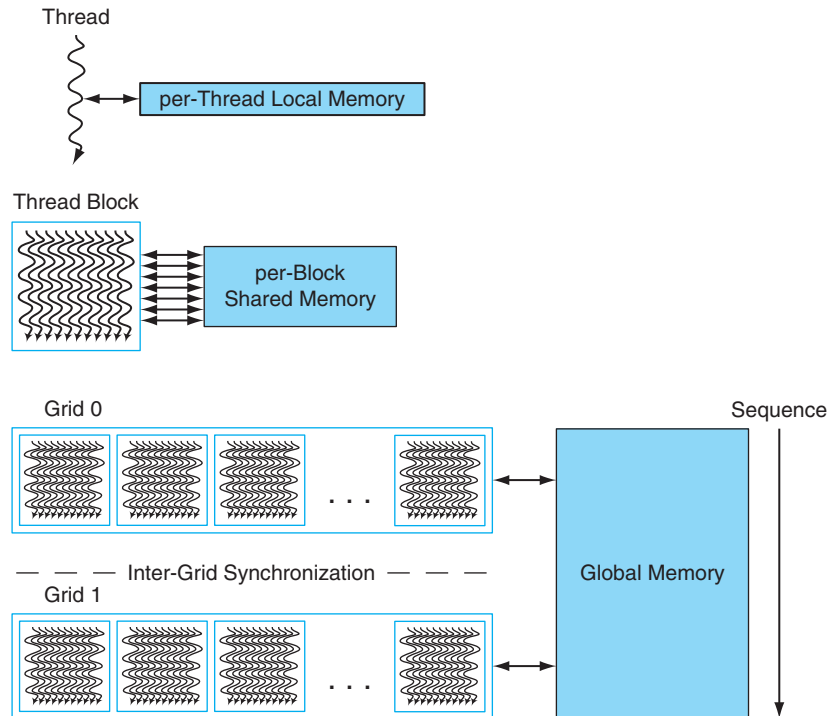

**FIGURE B.3.5** Nested granularity levels—thread, thread block, and grid—have corresponding memory sharing levels—local, shared, and global. Per-thread local memory is private to the thread. Per-block shared memory is shared by all threads of the block. Per-application global memory is shared by all threads.

### single-program multiple data (SPMD)

A style of parallel programming model in which all threads execute the same program. SPMD threads typically coordinate with barrier synchronization.

The CUDA programming model is similar in style to the familiar **single-program multiple data (SPMD)** model—it expresses parallelism explicitly, and each kernel executes on a fixed number of threads. However, CUDA is more flexible than most realizations of SPMD, because each kernel call dynamically creates a new grid with the right number of thread blocks and threads for that application step. The programmer can use a convenient degree of parallelism for each kernel, rather than having to design all phases of the computation to use the same number of threads. Figure B.3.6 shows an example of an SPMD-like CUDA code sequence. It first instantiates `kernelF` on a 2D grid of  $3 \times 2$  blocks where each 2D thread block consists of  $5 \times 3$  threads. It then instantiates `kernelG` on a 1D grid of four 1D thread blocks with six threads each. Because `kernelG` depends on the results of `kernelF`, they are separated by an interkernel synchronization barrier.

The concurrent threads of a thread block express fine-grained data parallelism and thread parallelism. The independent thread blocks of a grid express coarse-grained data parallelism. Independent grids express coarse-grained task parallelism. A kernel is simply C code for one thread of the hierarchy.

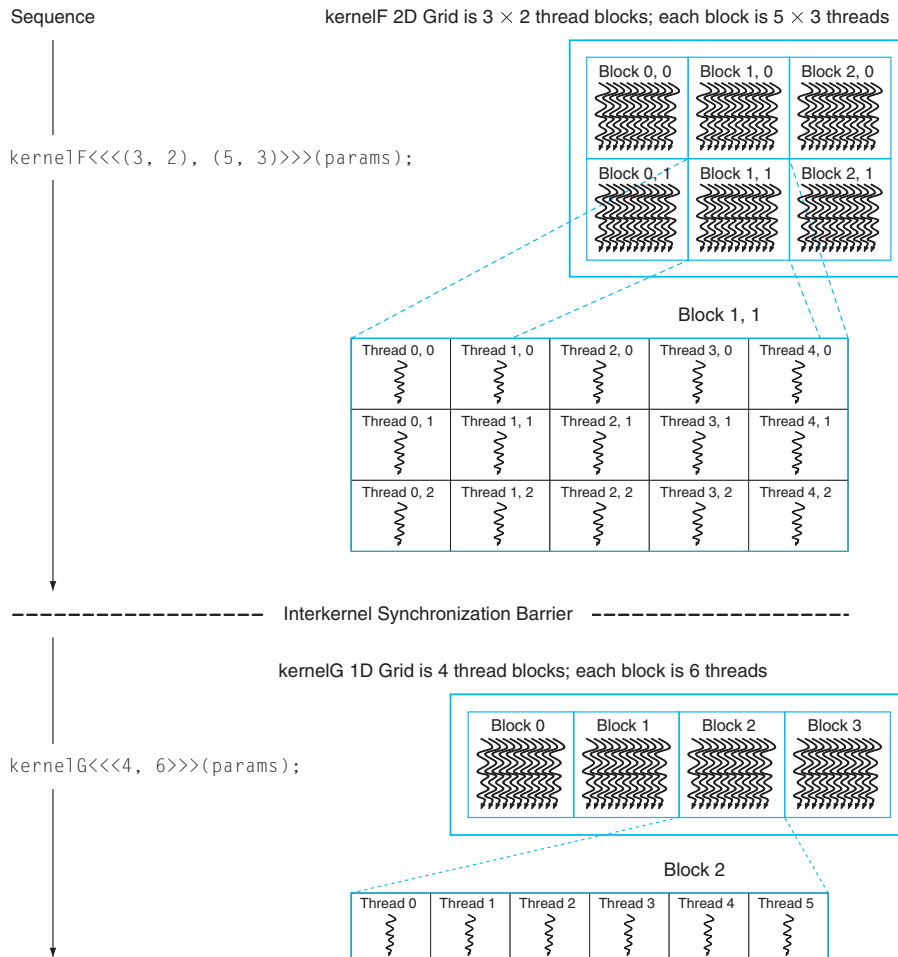

**FIGURE B.3.6** Sequence of kernel *F* instantiated on a 2D grid of 2D thread blocks, an interkernel synchronization barrier, followed by kernel *G* on a 1D grid of 1D thread blocks.

## Restrictions

For efficiency, and to simplify its implementation, the CUDA programming model has some restrictions. Threads and thread blocks may only be created by invoking a parallel kernel, not from within a parallel kernel. Together with the required independence of thread blocks, this makes it possible to execute CUDA programs with a simple scheduler that introduces minimal runtime overhead. In fact, the Tesla GPU architecture implements *hardware* management and scheduling of threads and thread blocks.

Task parallelism can be expressed at the thread block level but is difficult to express within a thread block because thread synchronization barriers operate on all the threads of the block. To enable CUDA programs to run on any number of processors, dependencies among thread blocks within the same kernel grid are not allowed—blocks must execute independently. Since CUDA requires that thread blocks be independent and allows blocks to be executed in any order, combining results generated by multiple blocks must in general be done by launching a second kernel on a new grid of thread blocks (although thread blocks may *coordinate* their activities using atomic memory operations on the global memory visible to all threads—by atomically incrementing queue pointers, for example).

Recursive function calls are not currently allowed in CUDA kernels. Recursion is unattractive in a massively parallel kernel, because providing stack space for the tens of thousands of threads that may be active would require substantial amounts of memory. Serial algorithms that are normally expressed using recursion, such as quicksort, are typically best implemented using nested data parallelism rather than explicit recursion.

To support a heterogeneous system architecture combining a CPU and a GPU, each with its own memory system, CUDA programs must copy data and results between host memory and device memory. The overhead of CPU–GPU interaction and data transfers is minimized by using DMA block transfer engines and fast interconnects. Compute-intensive problems large enough to need a GPU performance boost amortize the overhead better than small problems.

## Implications for Architecture

The parallel programming models for graphics and computing have driven GPU architecture to be different than CPU architecture. The key aspects of GPU programs driving GPU processor architecture are:

- *Extensive use of fine-grained data parallelism:* Shader programs describe how to process a single pixel or vertex, and CUDA programs describe how to compute an individual result.
- *Highly threaded programming model:* A shader thread program processes a single pixel or vertex, and a CUDA thread program may generate a single result. A GPU must create and execute millions of such thread programs per frame, at 60 frames per second.
- *Scalability:* A program must automatically increase its performance when provided with additional processors, without recompiling.
- *Intensive floating-point (or integer) computation.*
- *Support of high-throughput computations.*

**B.4****Multithreaded Multiprocessor Architecture**

To address different market segments, GPUs implement scalable numbers of multiprocessors—in fact, GPUs are multiprocessors composed of multiprocessors. Furthermore, each multiprocessor is highly multithreaded to execute many fine-grained vertex and pixel shader threads efficiently. A quality basic GPU has two to four multiprocessors, while a gaming enthusiast’s GPU or computing platform has dozens of them. This section looks at the architecture of one such multithreaded multiprocessor, a simplified version of the NVIDIA Tesla *streaming multiprocessor* (SM) described in Section B.7.

Why use a multiprocessor, rather than several independent processors? The parallelism within each multiprocessor provides localized high performance and supports extensive multithreading for the fine-grained parallel programming models described in Section B.3. The individual threads of a thread block execute together within a multiprocessor to share data. The multithreaded multiprocessor design we describe here has eight scalar processor cores in a tightly coupled architecture, and executes up to 512 threads (the SM described in Section B.7 executes up to 768 threads). For area and power efficiency, the multiprocessor shares large complex units among the eight processor cores, including the instruction cache, the multithreaded instruction unit, and the shared memory RAM.

**Massive Multithreading**

GPU processors are highly multithreaded to achieve several goals:

- Cover the latency of memory loads and texture fetches from DRAM
- Support fine-grained parallel graphics shader programming models
- Support fine-grained parallel computing programming models
- Virtualize the physical processors as threads and thread blocks to provide transparent scalability
- Simplify the parallel programming model to writing a serial program for one thread

Memory and texture fetch latency can require hundreds of processor clocks, because GPUs typically have small streaming caches rather than large working-set caches like CPUs. A fetch request generally requires a full DRAM access latency plus interconnect and buffering latency. Multithreading helps cover the latency with useful computing—while one thread is waiting for a load or texture fetch to complete, the processor can execute another thread. The fine-grained parallel programming models provide literally thousands of independent threads that can keep many processors busy despite the long memory latency seen by individual threads.



A graphics vertex or pixel shader program is a program for a single thread that processes a vertex or a pixel. Similarly, a CUDA program is a C program for a single thread that computes a result. Graphics and computing programs instantiate many parallel threads to render complex images and compute large result arrays. To dynamically balance shifting vertex and pixel shader thread workloads, each multiprocessor concurrently executes multiple different thread programs and different types of shader programs.

To support the independent vertex, primitive, and pixel programming model of graphics shading languages and the single-thread programming model of CUDA C/C++, each GPU thread has its own private registers, private per-thread memory, program counter, and thread execution state, and can execute an independent code path. To efficiently execute hundreds of concurrent lightweight threads, the GPU multiprocessor is hardware multithreaded—it manages and executes hundreds of concurrent threads in hardware without scheduling overhead. Concurrent threads within thread blocks can synchronize at a barrier with a single instruction. Lightweight thread creation, zero-overhead thread scheduling, and fast barrier synchronization efficiently support very fine-grained parallelism.

## Multiprocessor Architecture

A unified graphics and computing multiprocessor executes vertex, geometry, and pixel fragment shader programs, and parallel computing programs. As Figure B.4.1 shows, the example multiprocessor consists of eight *scalar processor* (SP) cores each with a large multithreaded *register file* (RF), two *special function units* (SFUs), a multithreaded instruction unit, an instruction cache, a read-only constant cache, and a shared memory.

The 16 KB shared memory holds graphics data buffers and shared computing data. CUDA variables declared as `__shared__` reside in the shared memory. To map the logical graphics pipeline workload through the multiprocessor multiple times, as shown in Section B.2, vertex, geometry, and pixel threads have independent input and output buffers, and workloads arrive and depart independently of thread execution.

Each SP core contains scalar integer and floating-point arithmetic units that execute most instructions. The SP is hardware multithreaded, supporting up to 64 threads. Each pipelined SP core executes one scalar instruction per thread per clock, which ranges from 1.2 GHz to 1.6 GHz in different GPU products. Each SP core has a large RF of 1024 general-purpose 32-bit registers, partitioned among its assigned threads. Programs declare their register demand, typically 16 to 64 scalar 32-bit registers per thread. The SP can concurrently run many threads that use a few registers or fewer threads that use more registers. The compiler optimizes register allocation to balance the cost of spilling registers versus the cost of fewer threads. Pixel shader programs often use 16 or fewer registers, enabling each SP to run up to 64 pixel shader threads to cover long-latency texture fetches. Compiled CUDA programs often need 32 registers per thread, limiting each SP to 32 threads, which limits such a kernel program to 256 threads per thread block on this example multiprocessor, rather than its maximum of 512 threads.

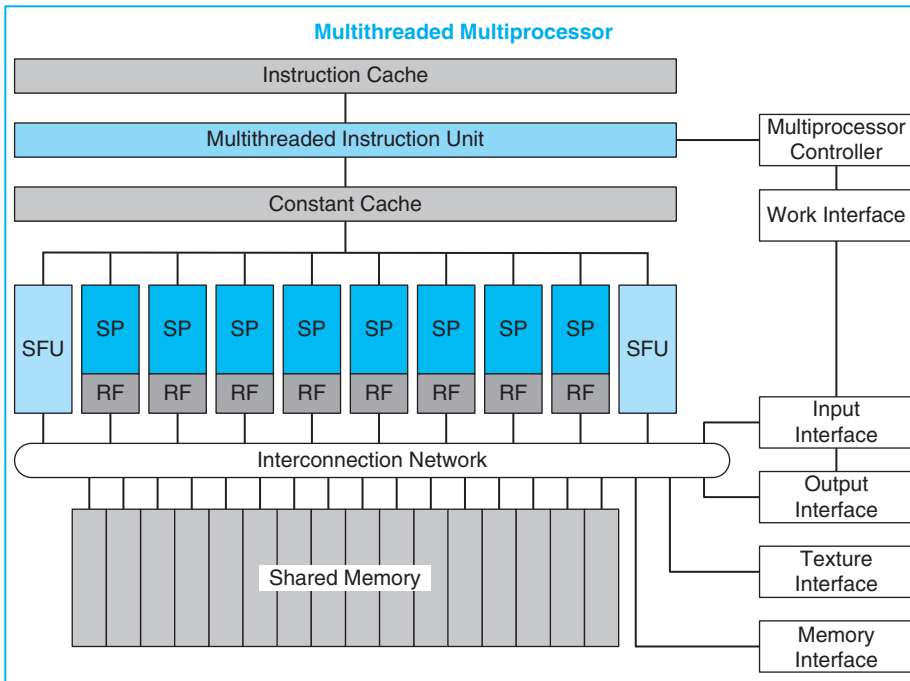

**FIGURE B.4.1 Multithreaded multiprocessor with eight scalar processor (SP) cores.** The eight SP cores each have a large multithreaded *register file* (RF) and share an instruction cache, multithreaded instruction issue unit, constant cache, two *special function units* (SFUs), interconnection network, and a multibank shared memory.

The pipelined SFUs execute thread instructions that compute special functions and interpolate pixel attributes from primitive vertex attributes. These instructions can execute concurrently with instructions on the SPs. The SFU is described later.

The multiprocessor executes texture fetch instructions on the texture unit via the texture interface, and uses the memory interface for external memory load, store, and atomic access instructions. These instructions can execute concurrently with instructions on the SPs. Shared memory access uses a low-latency interconnection network between the SP processors and the shared memory banks.

### Single-Instruction Multiple-Thread (SIMT)

To manage and execute hundreds of threads running several different programs efficiently, the multiprocessor employs a **single-instruction multiple-thread (SIMT)** architecture. It creates, manages, schedules, and executes concurrent threads in groups of parallel threads called *warps*. The term **warp** originates from weaving, the first parallel thread technology. The photograph in Figure B.4.2 shows a warp of parallel threads emerging from a loom. This example multiprocessor uses a SIMT warp size of 32 threads, executing four threads in each of the eight SP cores over four

#### single-instruction multiple-thread (SIMT)

A processor architecture that applies one instruction to multiple independent threads in parallel.

**warp** The set of parallel threads that execute the same instruction together in a SIMT architecture.

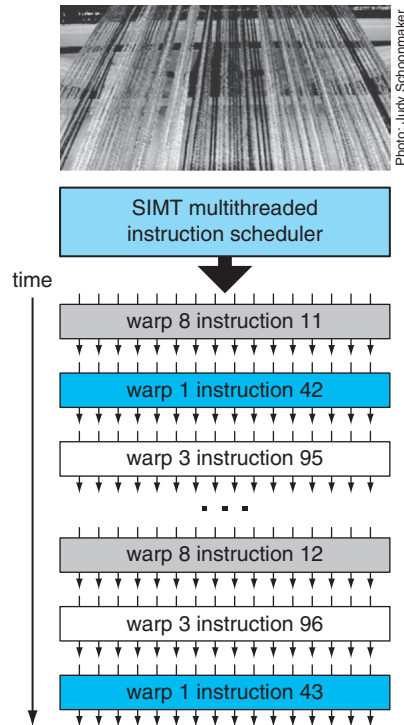

**FIGURE B.4.2 SIMT multithreaded warp scheduling.** The scheduler selects a ready warp and issues an instruction synchronously to the parallel threads composing the warp. Because warps are independent, the scheduler may select a different warp each time.

clocks. The Tesla SM multiprocessor described in Section B.7 also uses a warp size of 32 parallel threads, executing four threads per SP core for efficiency on plentiful pixel threads and computing threads. Thread blocks consist of one or more warps.

This example SIMT multiprocessor manages a pool of 16 warps, a total of 512 threads. Individual parallel threads composing a warp are the same type and start together at the same program address, but are otherwise free to branch and execute independently. At each instruction issue time, the SIMT multithreaded instruction unit selects a warp that is ready to execute its next instruction, and then issues that instruction to the active threads of that warp. A SIMT instruction is broadcast synchronously to the active parallel threads of a warp; individual threads may be inactive due to independent branching or predication. In this multiprocessor, each SP scalar processor core executes an instruction for four individual threads of a warp using four clocks, reflecting the 4:1 ratio of warp threads to cores.

SIMT processor architecture is akin to *single-instruction multiple data* (SIMD) design, which applies one instruction to multiple data lanes, but differs in that SIMT applies one instruction to multiple independent threads in parallel, not just

to multiple data lanes. An instruction for a SIMD processor controls a vector of multiple data lanes together, whereas an instruction for a SIMT processor controls an individual thread, and the SIMT instruction unit issues an instruction to a warp of independent parallel threads for efficiency. The SIMT processor finds data-level parallelism among threads at runtime, analogous to the way a superscalar processor finds instruction-level parallelism among instructions at runtime.

A SIMT processor realizes full efficiency and performance when all threads of a warp take the same execution path. If threads of a warp diverge via a data-dependent conditional branch, execution serializes for each branch path taken, and when all paths complete, the threads converge to the same execution path. For equal length paths, a divergent if-else code block is 50% efficient. The multiprocessor uses a branch synchronization stack to manage independent threads that diverge and converge. Different warps execute independently at full speed regardless of whether they are executing common or disjoint code paths. As a result, SIMT GPUs are dramatically more efficient and flexible on branching code than earlier GPUs, as their warps are much narrower than the SIMD width of prior GPUs.

In contrast with SIMD vector architectures, SIMT enables programmers to write thread-level parallel code for individual independent threads, as well as data-parallel code for many coordinated threads. For program correctness, the programmer can essentially ignore the SIMT execution attributes of warps; however, substantial performance improvements can be realized by taking care that the code seldom requires threads in a warp to diverge. In practice, this is analogous to the role of cache lines in traditional codes: cache line size can be safely ignored when designing for correctness but must be considered in the code structure when designing for peak performance.

## **SIMT Warp Execution and Divergence**

The SIMT approach of scheduling independent warps is more flexible than the scheduling of previous GPU architectures. A warp comprises parallel threads of the same type: vertex, geometry, pixel, or compute. The basic unit of pixel fragment shader processing is the 2-by-2 pixel quad implemented as four pixel shader threads. The multiprocessor controller packs the pixel quads into a warp. It similarly groups vertices and primitives into warps, and packs computing threads into a warp. A thread block comprises one or more warps. The SIMT design shares the instruction fetch and issue unit efficiently across parallel threads of a warp, but requires a full warp of active threads to get full performance efficiency.

This unified multiprocessor schedules and executes multiple warp types concurrently, allowing it to concurrently execute vertex and pixel warps. Its warp scheduler operates at less than the processor clock rate, because there are four thread lanes per processor core. During each scheduling cycle, it selects a warp to execute a SIMT warp instruction, as shown in Figure B.4.2. An issued warp-instruction executes as four sets of eight threads over four processor cycles of throughput. The processor pipeline uses several clocks of latency to complete each instruction. If the number of active warps times the clocks per warp exceeds the pipeline

latency, the programmer can ignore the pipeline latency. For this multiprocessor, a round-robin schedule of eight warps has a period of 32 cycles between successive instructions for the same warp. If the program can keep 256 threads active per multiprocessor, instruction latencies up to 32 cycles can be hidden from an individual sequential thread. However, with few active warps, the processor pipeline depth becomes visible and may cause processors to stall.

A challenging design problem is implementing zero-overhead warp scheduling for a dynamic mix of different warp programs and program types. The instruction scheduler must select a warp every four clocks to issue one instruction per clock per thread, equivalent to an IPC of 1.0 per processor core. Because warps are independent, the only dependences are among sequential instructions from the same warp. The scheduler uses a register dependency scoreboard to qualify warps whose active threads are ready to execute an instruction. It prioritizes all such ready warps and selects the highest priority one for issue. Prioritization must consider warp type, instruction type, and the desire to be fair to all active warps.

## Managing Threads and Thread Blocks

The multiprocessor controller and instruction unit manage threads and thread blocks. The controller accepts work requests and input data and arbitrates access to shared resources, including the texture unit, memory access path, and I/O paths. For graphics workloads, it creates and manages three types of graphics threads concurrently: vertex, geometry, and pixel. Each of the graphics work types has independent input and output paths. It accumulates and packs each of these input work types into SIMT warps of parallel threads executing the same thread program. It allocates a free warp, allocates registers for the warp threads, and starts warp execution in the multiprocessor. Every program declares its per-thread register demand; the controller starts a warp only when it can allocate the requested register count for the warp threads. When all the threads of the warp exit, the controller unpacks the results and frees the warp registers and resources.

The controller creates **cooperative thread arrays (CTAs)** which implement CUDA thread blocks as one or more warps of parallel threads. It creates a CTA when it can create all CTA warps and allocate all CTA resources. In addition to threads and registers, a CTA requires allocating shared memory and barriers. The program declares the required capacities, and the controller waits until it can allocate those amounts before launching the CTA. Then it creates CTA warps at the warp scheduling rate, so that a CTA program starts executing immediately at full multiprocessor performance. The controller monitors when all threads of a CTA have exited, and frees the CTA shared resources and its warp resources.

**cooperative thread array (CTA)** A set of concurrent threads that executes the same thread program and may cooperate to compute a result. A GPU CTA implements a CUDA thread block.

## Thread Instructions

The SP thread processors execute scalar instructions for individual threads, unlike earlier GPU vector instruction architectures, which executed four-component vector instructions for each vertex or pixel shader program. Vertex programs

generally compute (x, y, z, w) position vectors, while pixel shader programs compute (red, green, blue, alpha) color vectors. However, shader programs are becoming longer and more scalar, and it is increasingly difficult to fully occupy even two components of a legacy GPU four-component vector architecture. In effect, the SIMT architecture parallelizes across 32 independent pixel threads, rather than parallelizing the four vector components within a pixel. CUDA C/C++ programs have predominantly scalar code per thread. Previous GPUs employed vector packing (e.g., combining subvectors of work to gain efficiency) but that complicated the scheduling hardware as well as the compiler. Scalar instructions are simpler and compiler-friendly. Texture instructions remain vector-based, taking a source coordinate vector and returning a filtered color vector.

To support multiple GPUs with different binary microinstruction formats, high-level graphics and computing language compilers generate intermediate assembler-level instructions (e.g., Direct3D vector instructions or PTX scalar instructions), which are then optimized and translated to binary GPU microinstructions. The NVIDIA PTX (parallel thread execution) instruction set definition [2007] provides a stable target ISA for compilers, and provides compatibility over several generations of GPUs with evolving binary microinstruction-set architectures. The optimizer readily expands Direct3D vector instructions to multiple scalar binary microinstructions. PTX scalar instructions translate nearly one to one with scalar binary microinstructions, although some PTX instructions expand to multiple binary microinstructions, and multiple PTX instructions may fold into one binary microinstruction. Because the intermediate assembler-level instructions use virtual registers, the optimizer analyzes data dependencies and allocates real registers. The optimizer eliminates dead code, folds instructions together when feasible, and optimizes SIMT branch diverge and converge points.

## Instruction Set Architecture (ISA)

The thread ISA described here is a simplified version of the Tesla architecture PTX ISA, a register-based scalar instruction set comprising floating-point, integer, logical, conversion, special functions, flow control, memory access, and texture operations. Figure B.4.3 lists the basic PTX GPU thread instructions; see the NVIDIA PTX specification [2007] for details. The instruction format is:

```
opcode.type d, a, b, c;
```

where *d* is the destination operand, *a*, *b*, *c* are source operands, and *.type* is one of:

Type	.type Specifier
Untyped bits 8, 16, 32, and 64 bits	.b8, .b16, .b32, .b64
Unsigned integer 8, 16, 32, and 64 bits	.u8, .u16, .u32, .u64
Signed integer 8, 16, 32, and 64 bits	.s8, .s16, .s32, .s64
Floating-point 16, 32, and 64 bits	.f16, .f32, .f64

## Basic PTX GPU Thread Instructions

Group	Instruction	Example	Meaning	Comments
Arithmetic	arithmetic <i>.type</i> = <i>.s32, .u32, .f32, .s64, .u64, .f64</i>			
	<i>add.type</i>	<i>add.f32 d, a, b</i>	<i>d = a + b;</i>	
	<i>sub.type</i>	<i>sub.f32 d, a, b</i>	<i>d = a - b;</i>	
	<i>mul.type</i>	<i>mul.f32 d, a, b</i>	<i>d = a * b;</i>	
	<i>mad.type</i>	<i>mad.f32 d, a, b, c</i>	<i>d = a * b + c;</i>	multiply-add
	<i>div.type</i>	<i>div.f32 d, a, b</i>	<i>d = a / b;</i>	multiple microinstructions
	<i>rem.type</i>	<i>rem.u32 d, a, b</i>	<i>d = a % b;</i>	integer remainder
	<i>abs.type</i>	<i>abs.f32 d, a</i>	<i>d =  a ;</i>	
	<i>neg.type</i>	<i>neg.f32 d, a</i>	<i>d = 0 - a;</i>	
	<i>min.type</i>	<i>min.f32 d, a, b</i>	<i>d = (a &lt; b)? a:b;</i>	floating selects non-NaN
	<i>max.type</i>	<i>max.f32 d, a, b</i>	<i>d = (a &gt; b)? a:b;</i>	floating selects non-NaN
	<i>setp.cmp.type</i>	<i>setp.lt.f32 p, a, b</i>	<i>p = (a &lt; b);</i>	compare and set predicate
	numeric <i>.cmp</i> = <i>eq, ne, lt, le, gt, ge</i> ; unordered <i>cmp</i> = <i>equ, neu, ltu, leu, gtu, geu, num, nan</i>			
	<i>mov.type</i>	<i>mov.b32 d, a</i>	<i>d = a;</i>	move
<i>selp.type</i>	<i>selp.f32 d, a, b, p</i>	<i>d = p? a: b;</i>	select with predicate	
<i>cvt.dtype.atype</i>	<i>cvt.f32.s32 d, a</i>	<i>d = convert(a);</i>	convert <i>atype</i> to <i>dtype</i>	
Special Function	special <i>.type</i> = <i>.f32</i> (some <i>.f64</i> )			
	<i>rcp.type</i>	<i>rcp.f32 d, a</i>	<i>d = 1/a;</i>	reciprocal
	<i>sqrt.type</i>	<i>sqrt.f32 d, a</i>	<i>d = sqrt(a);</i>	square root
	<i>rsqrt.type</i>	<i>rsqrt.f32 d, a</i>	<i>d = 1/sqrt(a);</i>	reciprocal square root
	<i>sin.type</i>	<i>sin.f32 d, a</i>	<i>d = sin(a);</i>	sine
	<i>cos.type</i>	<i>cos.f32 d, a</i>	<i>d = cos(a);</i>	cosine
	<i>lg2.type</i>	<i>lg2.f32 d, a</i>	<i>d = log(a)/log(2)</i>	binary logarithm
<i>ex2.type</i>	<i>ex2.f32 d, a</i>	<i>d = 2 ** a;</i>	binary exponential	
Logical	logic <i>.type</i> = <i>.pred, .b32, .b64</i>			
	<i>and.type</i>	<i>and.b32 d, a, b</i>	<i>d = a &amp; b;</i>	
	<i>or.type</i>	<i>or.b32 d, a, b</i>	<i>d = a   b;</i>	
	<i>xor.type</i>	<i>xor.b32 d, a, b</i>	<i>d = a ^ b;</i>	
	<i>not.type</i>	<i>not.b32 d, a, b</i>	<i>d = ~a;</i>	one's complement
	<i>cnot.type</i>	<i>cnot.b32 d, a, b</i>	<i>d = (a==0)? 1:0;</i>	C logical not
	<i>shl.type</i>	<i>shl.b32 d, a, b</i>	<i>d = a &lt;&lt; b;</i>	shift left
<i>shr.type</i>	<i>shr.s32 d, a, b</i>	<i>d = a &gt;&gt; b;</i>	shift right	
Memory Access	memory <i>.space</i> = <i>.global, .shared, .local, .const</i> ; <i>.type</i> = <i>.b8, .u8, .s8, .b16, .b32, .b64</i>			
	<i>ld.space.type</i>	<i>ld.global.b32 d, [a+off]</i>	<i>d = *(a+off);</i>	load from memory <i>space</i>
	<i>st.space.type</i>	<i>st.shared.b32 [d+off], a</i>	<i>*(d+off) = a;</i>	store to memory <i>space</i>
	<i>tex.nd.dtype.btype</i>	<i>tex.2d.v4.f32.f32 d, a, b</i>	<i>d = tex2d(a, b);</i>	texture lookup
	<i>atom.spc.op.type</i>	<i>atom.global.add.u32 d,[a], b</i> <i>atom.global.cas.b32 d,[a], b, c</i>	<i>atomic { d = *a;</i> <i>*a = op(*a, b); }</i>	atomic read-modify-write operation
<i>atom.op</i> = <i>and, or, xor, add, min, max, exch, cas</i> ; <i>.spc</i> = <i>.global</i> ; <i>.type</i> = <i>.b32</i>				
Control Flow	<i>branch</i>	<i>@p bra target</i>	<i>if (p) goto target;</i>	conditional branch
	<i>call</i>	<i>call (ret), func, (params)</i>	<i>ret = func(params);</i>	call function
	<i>ret</i>	<i>ret</i>	<i>return;</i>	return from function call
	<i>bar.sync</i>	<i>bar.sync d</i>	<i>wait for threads</i>	barrier synchronization
	<i>exit</i>	<i>exit</i>	<i>exit;</i>	terminate thread execution

FIGURE B.4.3 Basic PTX GPU thread instructions.



Source operands are scalar 32-bit or 64-bit values in registers, an immediate value, or a constant; predicate operands are 1-bit Boolean values. Destinations are registers, except for store to memory. Instructions are predicated by prefixing them with `@p` or `!p`, where `p` is a predicate register. Memory and texture instructions transfer scalars or vectors of two to four components, up to 128 bits in total. PTX instructions specify the behavior of one thread.

The PTX arithmetic instructions operate on 32-bit and 64-bit floating-point, signed integer, and unsigned integer types. Recent GPUs support 64-bit double-precision floating-point; see Section B.6. On current GPUs, PTX 64-bit integer and logical instructions are translated to two or more binary microinstructions that perform 32-bit operations. The GPU special function instructions are limited to 32-bit floating-point. The thread control flow instructions are conditional branch, function call and return, thread exit, and `bar.sync` (barrier synchronization). The conditional branch instruction `@p bra target` uses a predicate register `p` (or `!p`) previously set by a compare and set predicate `setp` instruction to determine whether the thread takes the branch or not. Other instructions can also be predicated on a predicate register being true or false.

### Memory Access Instructions

The `tex` instruction fetches and filters texture samples from 1D, 2D, and 3D texture arrays in memory via the texture subsystem. Texture fetches generally use interpolated floating-point coordinates to address a texture. Once a graphics pixel shader thread computes its pixel fragment color, the raster operations processor blends it with the pixel color at its assigned  $(x, y)$  pixel position and writes the final color to memory.

To support computing and C/C++ language needs, the Tesla PTX ISA implements memory load/store instructions. It uses integer byte addressing with register plus offset address arithmetic to facilitate conventional compiler code optimizations. Memory load/store instructions are common in processors, but are a significant new capability in the Tesla architecture GPUs, as prior GPUs provided only the texture and pixel accesses required by the graphics APIs.

For computing, the load/store instructions access three read/write memory spaces that implement the corresponding CUDA memory spaces in Section B.3:

- Local memory for per-thread private addressable temporary data (implemented in external DRAM)
- Shared memory for low-latency access to data shared by cooperating threads in the same CTA/thread block (implemented in on-chip SRAM)
- Global memory for large data sets shared by all threads of a computing application (implemented in external DRAM)

The memory load/store instructions `ld.global`, `st.global`, `ld.shared`, `st.shared`, `ld.local`, and `st.local` access the global, shared, and local memory spaces. Computing programs use the fast barrier synchronization instruction `bar.sync` to synchronize threads within a CTA/thread block that communicate with each other via shared and global memory.



To improve memory bandwidth and reduce overhead, the local and global load/store instructions coalesce individual parallel thread requests from the same SIMT warp together into a single memory block request when the addresses fall in the same block and meet alignment criteria. Coalescing memory requests provides a significant performance boost over separate requests from individual threads. The multiprocessor's large thread count, together with support for many outstanding load requests, helps cover load-to-use latency for local and global memory implemented in external DRAM.

The latest Tesla architecture GPUs also provide efficient atomic memory operations on memory with the `atom.op.u32` instructions, including integer operations `add`, `min`, `max`, `and`, `or`, `xor`, `exchange`, and `cas` (compare-and-swap) operations, facilitating parallel reductions and parallel data structure management.

### Barrier Synchronization for Thread Communication

Fast barrier synchronization permits CUDA programs to communicate frequently via shared memory and global memory by simply calling `__syncthreads()`; as part of each interthread communication step. The synchronization intrinsic function generates a single `bar.sync` instruction. However, implementing fast barrier synchronization among up to 512 threads per CUDA thread block is a challenge.

Grouping threads into SIMT warps of 32 threads reduces the synchronization difficulty by a factor of 32. Threads wait at a barrier in the SIMT thread scheduler so they do not consume any processor cycles while waiting. When a thread executes a `bar.sync` instruction, it increments the barrier's thread arrival counter and the scheduler marks the thread as waiting at the barrier. Once all the CTA threads arrive, the barrier counter matches the expected terminal count, and the scheduler releases all the threads waiting at the barrier and resumes executing threads.

### Streaming Processor (SP)

The multithreaded *streaming processor* (SP) core is the primary thread instruction processor in the multiprocessor. Its *register file* (RF) provides 1024 scalar 32-bit registers for up to 64 threads. It executes all the fundamental floating-point operations, including `add.f32`, `mul.f32`, `mad.f32` (floating multiply-add), `min.f32`, `max.f32`, and `setp.f32` (floating compare and set predicate). The floating-point add and multiply operations are compatible with the IEEE 754 standard for single-precision FP numbers, including *not-a-number* (NaN) and infinity values. The SP core also implements all of the 32-bit and 64-bit integer arithmetic, comparison, conversion, and logical PTX instructions shown in Figure B.4.3.

The floating-point add and `mul` operations employ IEEE round-to-nearest-even as the default rounding mode. The `mad.f32` floating-point multiply-add operation performs a multiplication with truncation, followed by an addition with round-to-nearest-even. The SP flushes input denormal operands to sign-preserved-zero. Results that underflow the target output exponent range are flushed to sign-preserved-zero after rounding.

## Special Function Unit (SFU)

Certain thread instructions can execute on the SFUs, concurrently with other thread instructions executing on the SPs. The SFU implements the special function instructions of Figure B.4.3, which compute 32-bit floating-point approximations to reciprocal, reciprocal square root, and key transcendental functions. It also implements 32-bit floating-point planar attribute interpolation for pixel shaders, providing accurate interpolation of attributes such as color, depth, and texture coordinates.

Each pipelined SFU generates one 32-bit floating-point special function result per cycle; the two SFUs per multiprocessor execute special function instructions at a quarter the simple instruction rate of the eight SPs. The SFUs also execute the `mul.f32` multiply instruction concurrently with the eight SPs, increasing the peak computation rate up to 50% for threads with a suitable instruction mixture.

For functional evaluation, the Tesla architecture SFU employs quadratic interpolation based on enhanced minimax approximations for approximating the reciprocal, reciprocal square-root,  $\log_2 x$ ,  $2x$ , and  $\sin/\cos$  functions. The accuracy of the function estimates ranges from 22 to 24 mantissa bits. See Section B.6 for more details on SFU arithmetic.

## Comparing with Other Multiprocessors

Compared with SIMD vector architectures such as x86 SSE, the SIMT multiprocessor can execute individual threads independently, rather than always executing them together in synchronous groups. SIMT hardware finds data parallelism among independent threads, whereas SIMD hardware requires the software to express data parallelism explicitly in each vector instruction. A SIMT machine executes a warp of 32 threads synchronously when the threads take the same execution path, yet can execute each thread independently when they diverge. The advantage is significant because SIMT programs and instructions simply describe the behavior of a single independent thread, rather than a SIMD data vector of four or more data lanes. Yet the SIMT multiprocessor has SIMD-like efficiency, spreading the area and cost of one instruction unit across the 32 threads of a warp and across the eight streaming processor cores. SIMT provides the performance of SIMD together with the productivity of multithreading, avoiding the need to explicitly code SIMD vectors for edge conditions and partial divergence.

The SIMT multiprocessor imposes little overhead because it is hardware multithreaded with hardware barrier synchronization. That allows graphics shaders and CUDA threads to express very fine-grained parallelism. Graphics and CUDA programs use threads to express fine-grained data parallelism in a per-thread program, rather than forcing the programmer to express it as SIMD vector instructions. It is simpler and more productive to develop scalar single-thread code than vector code, and the SIMT multiprocessor executes the code with SIMD-like efficiency.

Coupling eight streaming processor cores together closely into a multiprocessor and then implementing a scalable number of such multiprocessors makes a two-level multiprocessor composed of multiprocessors. The CUDA programming model exploits the two-level hierarchy by providing individual threads for fine-grained parallel computations, and by providing grids of thread blocks for coarse-grained parallel operations. The same thread program can provide both fine-grained and coarse-grained operations. In contrast, CPUs with SIMD vector instructions must use two different programming models to provide fine-grained and coarse-grained operations: coarse-grained parallel threads on different cores, and SIMD vector instructions for fine-grained data parallelism.

### Multithreaded Multiprocessor Conclusion

The example GPU multiprocessor based on the Tesla architecture is highly multithreaded, executing a total of up to 512 lightweight threads concurrently to support fine-grained pixel shaders and CUDA threads. It uses a variation on SIMD architecture and multithreading called SIMT (*single-instruction multiple-thread*) to efficiently broadcast one instruction to a warp of 32 parallel threads, while permitting each thread to branch and execute independently. Each thread executes its instruction stream on one of the eight *streaming processor* (SP) cores, which are multithreaded up to 64 threads.

The PTX ISA is a register-based load/store scalar ISA that describes the execution of a single thread. Because PTX instructions are optimized and translated to binary microinstructions for a specific GPU, the hardware instructions can evolve rapidly without disrupting compilers and software tools that generate PTX instructions.

## B.5 Parallel Memory System

Outside of the GPU itself, the memory subsystem is the most important determiner of the performance of a graphics system. Graphics workloads demand very high transfer rates to and from memory. Pixel write and blend (read-modify-write) operations, depth buffer reads and writes, and texture map reads, as well as command and object vertex and attribute data reads, comprise the majority of memory traffic.

Modern GPUs are highly parallel, as shown in Figure B.2.5. For example, the GeForce 8800 can process 32 pixels per clock, at 600 MHz. Each pixel typically requires a color read and write and a depth read and write of a 4-byte pixel. Usually an average of two or three texels of four bytes each are read to generate the pixel's color. So for a typical case, there is a demand of 28 bytes times 32 pixels = 896 bytes per clock. Clearly the bandwidth demand on the memory system is enormous.

To supply these requirements, GPU memory systems have the following characteristics:

- They are wide, meaning there are a large number of pins to convey data between the GPU and its memory devices, and the memory array itself comprises many DRAM chips to provide the full total data bus width.
- They are fast, meaning aggressive signaling techniques are used to maximize the data rate (bits/second) per pin.
- GPUs seek to use every available cycle to transfer data to or from the memory array. To achieve this, GPUs specifically do not aim to minimize latency to the memory system. High throughput (utilization efficiency) and short latency are fundamentally in conflict.
- Compression techniques are used, both lossy, of which the programmer must be aware, and lossless, which is invisible to the application and opportunistic.
- Caches and work coalescing structures are used to reduce the amount of off-chip traffic needed and to ensure that cycles spent moving data are used as fully as possible.

## DRAM Considerations

GPUs must take into account the unique characteristics of DRAM. DRAM chips are internally arranged as multiple (typically four to eight) banks, where each bank includes a power-of-2 number of rows (typically around 16,384), and each row contains a power-of-2 number of bits (typically 8192). DRAMs impose a variety of timing requirements on their controlling processor. For example, dozens of cycles are required to activate one row, but once activated, the bits within that row are randomly accessible with a new column address every four clocks. *Double-data rate* (DDR) synchronous DRAMs transfer data on both rising and falling edges of the interface clock (see Chapter 5). So a 1 GHz clocked DDR DRAM transfers data at 2 gigabits per second per data pin. Graphics DDR DRAMs usually have 32 bidirectional data pins, so eight bytes can be read or written from the DRAM per clock.

GPUs internally have a large number of generators of memory traffic. Different stages of the logical graphics pipeline each have their own request streams: command and vertex attribute fetch, shader texture fetch and load/store, and pixel depth and color read-write. At each logical stage, there are often multiple independent units to deliver the parallel throughput. These are each independent memory requestors. When viewed at the memory system, there is an enormous number of uncorrelated requests in flight. This is a natural mismatch to the reference pattern preferred by the DRAMs. A solution is for the GPU's memory controller to maintain separate heaps of traffic bound for different DRAM banks, and wait until enough traffic for

a particular DRAM row is pending before activating that row and transferring all the traffic at once. Note that accumulating pending requests, while good for DRAM row locality and thus efficient use of the data bus, leads to longer average latency as seen by the requestors whose requests spend time waiting for others. The design must take care that no particular request waits too long, otherwise some processing units can starve waiting for data and ultimately cause neighboring processors to become idle.

GPU memory subsystems are arranged as multiple *memory partitions*, each of which comprises a fully independent memory controller and one or two DRAM devices that are fully and exclusively owned by that partition. To achieve the best load balance and therefore approach the theoretical performance of  $n$  partitions, addresses are finely interleaved evenly across all memory partitions. The partition interleaving stride is typically a block of a few hundred bytes. The number of memory partitions is designed to balance the number of processors and other memory requesters.

## Caches

GPU workloads typically have very large working sets—on the order of hundreds of megabytes to generate a single graphics frame. Unlike with CPUs, it is not practical to construct caches on chips large enough to hold anything close to the full working set of a graphics application. Whereas CPUs can assume very high cache hit rates (99.9% or more), GPUs experience hit rates closer to 90% and must therefore cope with many misses in flight. While a CPU can reasonably be designed to halt while waiting for a rare cache miss, a GPU needs to proceed with misses and hits intermingled. We call this a *streaming cache architecture*.

GPU caches must deliver very high-bandwidth to their clients. Consider the case of a texture cache. A typical texture unit may evaluate two bilinear interpolations for each of four pixels per clock cycle, and a GPU may have many such texture units all operating independently. Each bilinear interpolation requires four separate texels, and each texel might be a 64-bit value. Four 16-bit components are typical. Thus, total bandwidth is  $2 \times 4 \times 4 \times 64 = 2048$  bits per clock. Each separate 64-bit texel is independently addressed, so the cache needs to handle 32 unique addresses per clock. This naturally favors a multibank and/or multiport arrangement of SRAM arrays.

## MMU

Modern GPUs are capable of translating virtual addresses to physical addresses. On the GeForce 8800, all processing units generate memory addresses in a 40-bit virtual address space. For computing, load and store thread instructions use 32-bit byte addresses, which are extended to a 40-bit virtual address by adding a 40-bit offset. A memory management unit performs virtual to physical address

translation; hardware reads the page tables from local memory to respond to misses on behalf of a hierarchy of translation lookaside buffers spread out among the processors and rendering engines. In addition to physical page bits, GPU page table entries specify the compression algorithm for each page. Page sizes range from 4 to 128 kilobytes.

## Memory Spaces

As introduced in Section B.3, CUDA exposes different memory spaces to allow the programmer to store data values in the most performance-optimal way. For the following discussion, NVIDIA Tesla architecture GPUs are assumed.

### Global memory

Global memory is stored in external DRAM; it is not local to any one physical *streaming multiprocessor* (SM) because it is meant for communication among different CTAs (thread blocks) in different grids. In fact, the many CTAs that reference a location in global memory may not be executing in the GPU at the same time; by design, in CUDA a programmer does not know the relative order in which CTAs are executed. Because the address space is evenly distributed among all memory partitions, there must be a read/write path from any streaming multiprocessor to any DRAM partition.

Access to global memory by different threads (and different processors) is not guaranteed to have sequential consistency. Thread programs see a relaxed memory ordering model. Within a thread, the order of memory reads and writes to the same address is preserved, but the order of accesses to different addresses may not be preserved. Memory reads and writes requested by different threads are unordered. Within a CTA, the barrier synchronization instruction `bar.sync` can be used to obtain strict memory ordering among the threads of the CTA. The `membar` thread instruction provides a memory barrier/fence operation that commits prior memory accesses and makes them visible to other threads before proceeding. Threads can also use the atomic memory operations described in Section B.4 to coordinate work on memory they share.

### Shared memory

Per-CTA shared memory is only visible to the threads that belong to that CTA, and shared memory only occupies storage from the time a CTA is created to the time it terminates. Shared memory can therefore reside on-chip. This approach has many benefits. First, shared memory traffic does not need to compete with limited off-chip bandwidth needed for global memory references. Second, it is practical to build very high-bandwidth memory structures on-chip to support the read/write demands of each streaming multiprocessor. In fact, the shared memory is closely coupled to the streaming multiprocessor.

Each streaming multiprocessor contains eight physical thread processors. During one shared memory clock cycle, each thread processor can process two threads' worth of instructions, so 16 threads' worth of shared memory requests must be handled in each clock. Because each thread can generate its own addresses, and the addresses are typically unique, the shared memory is built using 16 independently addressable SRAM banks. For common access patterns, 16 banks are sufficient to maintain throughput, but pathological cases are possible; for example, all 16 threads might happen to access a different address on one SRAM bank. It must be possible to route a request from any thread lane to any bank of SRAM, so a 16-by-16 interconnection network is required.

### **Local Memory**

Per-thread local memory is private memory visible only to a single thread. Local memory is architecturally larger than the thread's register file, and a program can compute addresses into local memory. To support large allocations of local memory (recall the total allocation is the per-thread allocation times the number of active threads), local memory is allocated in external DRAM.

Although global and per-thread local memory reside off-chip, they are well-suited to being cached on-chip.

### **Constant Memory**

Constant memory is read-only to a program running on the SM (it can be written via commands to the GPU). It is stored in external DRAM and cached in the SM. Because commonly most or all threads in a SIMT warp read from the same address in constant memory, a single address lookup per clock is sufficient. The constant cache is designed to broadcast scalar values to threads in each warp.

### **Texture Memory**

Texture memory holds large read-only arrays of data. Textures for computing have the same attributes and capabilities as textures used with 3D graphics. Although textures are commonly two-dimensional images (2D arrays of pixel values), 1D (linear) and 3D (volume) textures are also available.

A compute program references a texture using a `tex` instruction. Operands include an identifier to name the texture, and one, two, or three coordinates based on the texture dimensionality. The floating-point coordinates include a fractional portion that specifies a sample location, often in-between texel locations. Noninteger coordinates invoke a bilinear weighted interpolation of the four closest values (for a 2D texture) before the result is returned to the program.

Texture fetches are cached in a streaming cache hierarchy designed to optimize throughput of texture fetches from thousands of concurrent threads. Some programs use texture fetches as a way to cache global memory.



## Surfaces

*Surface* is a generic term for a one-dimensional, two-dimensional, or three-dimensional array of pixel values and an associated format. A variety of formats are defined; for example, a pixel may be defined as four 8-bit RGBA integer components, or four 16-bit floating-point components. A program kernel does not need to know the surface type. A `tex` instruction recasts its result values as floating-point, depending on the surface format.

## Load/Store Access

Load/store instructions with integer byte addressing enable the writing and compiling of programs in conventional languages like C and C++. CUDA programs use load/store instructions to access memory.

To improve memory bandwidth and reduce overhead, the local and global load/store instructions coalesce individual parallel thread requests from the same warp together into a single memory block request when the addresses fall in the same block and meet alignment criteria. Coalescing individual small memory requests into large block requests provides a significant performance boost over separate requests. The large thread count, together with support for many outstanding load requests, helps cover load-to-use latency for local and global memory implemented in external DRAM.

## ROP

As shown in Figure B.2.5, NVIDIA Tesla architecture GPUs comprise a scalable *streaming processor array* (SPA), which performs all of the GPU's programmable calculations, and a scalable memory system, which comprises external DRAM control and fixed function *Raster Operation Processors* (ROPs) that perform color and depth framebuffer operations directly on memory. Each ROP unit is paired with a specific memory partition. ROP partitions are fed from the SMs via an interconnection network. Each ROP is responsible for depth and stencil tests and updates, as well as color blending. The ROP and memory controllers cooperate to implement lossless color and depth compression (up to 8:1) to reduce external bandwidth demand. ROP units also perform atomic operations on memory.

## B.6

## Floating-point Arithmetic

GPUs today perform most arithmetic operations in the programmable processor cores using IEEE 754-compatible single precision 32-bit floating-point operations (see Chapter 3). The fixed-point arithmetic of early GPUs was succeeded by 16-bit, 24-bit, and 32-bit floating-point, then IEEE 754-compatible 32-bit floating-point.



Some fixed-function logic within a GPU, such as texture-filtering hardware, continues to use proprietary numeric formats. Recent GPUs also provide IEEE 754-compatible double-precision 64-bit floating-point instructions.

## Supported Formats

The IEEE 754 standard for floating-point arithmetic specifies basic and storage formats. GPUs use two of the basic formats for computation, 32-bit and 64-bit binary floating-point, commonly called single precision and double precision. The standard also specifies a 16-bit binary storage floating-point format, **half precision**. GPUs and the Cg shading language employ the narrow 16-bit half data format for efficient data storage and movement, while maintaining high dynamic range. GPUs perform many texture filtering and pixel blending computations at half precision within the texture filtering unit and the raster operations unit. The OpenEXR high dynamic-range image file format developed by Industrial Light and Magic [2003] uses the identical half format for color component values in computer imaging and motion picture applications.

**half precision** A 16-bit binary floating-point format, with 1 sign bit, 5-bit exponent, 10-bit fraction, and an implied integer bit.

## Basic Arithmetic

Common single-precision floating-point operations in GPU programmable cores include addition, multiplication, **multiply-add**, minimum, maximum, compare, set predicate, and conversions between integer and floating-point numbers. Floating-point instructions often provide source operand modifiers for negation and absolute value.

**multiply-add (MAD)**  
A single floating-point instruction that performs a compound operation: multiplication followed by addition.

The floating-point addition and multiplication operations of most GPUs today are compatible with the IEEE 754 standard for single precision FP numbers, including *not-a-number* (NaN) and infinity values. The FP addition and multiplication operations use IEEE round-to-nearest-even as the default rounding mode. To increase floating-point instruction throughput, GPUs often use a compound multiply-add instruction (`mad`). The multiply-add operation performs FP multiplication with truncation, followed by FP addition with round-to-nearest-even. It provides two floating-point operations in one issuing cycle, without requiring the instruction scheduler to dispatch two separate instructions, but the computation is not fused and truncates the product before the addition. This makes it different from the fused multiply-add instruction discussed in Chapter 3 and later in this section. GPUs typically flush denormalized source operands to sign-preserved zero, and they flush results that underflow the target output exponent range to sign-preserved zero after rounding.

## Specialized Arithmetic

GPUs provide hardware to accelerate special function computation, attribute interpolation, and texture filtering. Special function instructions include cosine,

sine, binary exponential, binary logarithm, reciprocal, and reciprocal square root. Attribute interpolation instructions provide efficient generation of pixel attributes, derived from plane equation evaluation. The **special function unit (SFU)** introduced in Section B.4 computes special functions and interpolates planar attributes [Oberman and Siu, 2005].

Several methods exist for evaluating special functions in hardware. It has been shown that quadratic interpolation based on Enhanced Minimax Approximations is a very efficient method for approximating functions in hardware, including reciprocal, reciprocal square-root,  $\log_2 x$ ,  $2^x$ , sin, and cos.

We can summarize the method of SFU quadratic interpolation. For a binary input operand  $X$  with  $n$ -bit significand, the significand is divided into two parts:  $X_u$  is the upper part containing  $m$  bits, and  $X_l$  is the lower part containing  $n-m$  bits. The upper  $m$  bits  $X_u$  are used to consult a set of three lookup tables to return three finite-word coefficients  $C_0$ ,  $C_1$ , and  $C_2$ . Each function to be approximated requires a unique set of tables. These coefficients are used to approximate a given function  $f(X)$  in the range  $X_u \leq X < X_u + 2^{-m}$  by evaluating the expression:

$$f(X) = C_0 + C_1 X_l + C_2 X_l^2$$

The accuracy of each of the function estimates ranges from 22 to 24 significand bits. Example function statistics are shown in Figure B.6.1.

The IEEE 754 standard specifies exact-rounding requirements for division and square root; however, for many GPU applications, exact compliance is not required. Rather, for those applications, higher computational throughput is more important than last-bit accuracy. For the SFU special functions, the CUDA math library provides both a full accuracy function and a fast function with the SFU instruction accuracy.

Another specialized arithmetic operation in a GPU is attribute interpolation. Key *attributes* are usually specified for vertices of primitives that make up a scene to be rendered. Example attributes are color, depth, and texture coordinates. These attributes must be interpolated in the  $(x,y)$  screen space as needed to determine the

**special function unit (SFU)** A hardware unit that computes special functions and interpolates planar attributes.

Function	Input interval	Accuracy (good bits)	ULP* error	% exactly rounded	Monotonic
$1/x$	[1, 2)	24.02	0.98	87	Yes
$1/\text{sqrt}(x)$	[1, 4)	23.40	1.52	78	Yes
$2^x$	[0, 1)	22.51	1.41	74	Yes
$\log_2 x$	[1, 2)	22.57	N/A**	N/A	Yes
sin/cos	[0, $\pi/2$ )	22.47	N/A	N/A	No

\*ULP: unit in the last place.\*\*N/A: not applicable.

**FIGURE B.6.1 Special function approximation statistics.** For the NVIDIA GeForce 8800 *special function unit (SFU)*.

values of the attributes at each pixel location. The value of a given attribute  $U$  in an  $(x, y)$  plane can be expressed using plane equations of the form:

$$U(x, y) = A_u x + B_u y + C_u$$

where  $A$ ,  $B$ , and  $C$  are interpolation parameters associated with each attribute  $U$ . The interpolation parameters  $A$ ,  $B$ , and  $C$  are all represented as single-precision floating-point numbers.

Given the need for both a function evaluator and an attribute interpolator in a pixel shader processor, a single SFU that performs both functions for efficiency can be designed. Both functions use a sum of products operation to interpolate results, and the number of terms to be summed in both functions is very similar.

### Texture Operations

Texture mapping and filtering is another key set of specialized floating-point arithmetic operations in a GPU. The operations used for texture mapping include:

1. Receive texture address  $(s, t)$  for the current screen pixel  $(x, y)$ , where  $s$  and  $t$  are single-precision floating-point numbers.
2. Compute the level of detail to identify the correct texture **MIP-map** level.
3. Compute the trilinear interpolation fraction.
4. Scale texture address  $(s, t)$  for the selected MIP-map level.
5. Access memory and retrieve desired texels (texture elements).
6. Perform filtering operation on texels.

**MIP-map** A Latin phrase *multum in parvo*, or much in a small space. A MIP-map contains precalculated images of different resolutions, used to increase rendering speed and reduce artifacts.

Texture mapping requires a significant amount of floating-point computation for full-speed operation, much of which is done at 16-bit half precision. As an example, the GeForce 8800 Ultra delivers about 500 GFLOPS of proprietary format floating-point computation for texture mapping instructions, in addition to its conventional IEEE single-precision floating-point instructions. For more details on texture mapping and filtering, see Foley and van Dam [1995].

### Performance

The floating-point addition and multiplication arithmetic hardware is fully pipelined, and latency is optimized to balance delay and area. While pipelined, the throughput of the special functions is less than the floating-point addition and multiplication operations. Quarter-speed throughput for the special functions is typical performance in modern GPUs, with one SFU shared by four SP cores. In contrast, CPUs typically have significantly lower throughput for similar functions, such as division and square root, albeit with more accurate results. The attribute interpolation hardware is typically fully pipelined to enable full-speed pixel shaders.

## Double precision

Newer GPUs such as the Tesla T10P also support IEEE 754 64-bit double-precision operations in hardware. Standard floating-point arithmetic operations in double precision include addition, multiplication, and conversions between different floating-point and integer formats. The 2008 IEEE 754 floating-point standard includes specification for the *fused-multiply-add* (FMA) operation, as discussed in Chapter 3. The FMA operation performs a floating-point multiplication followed by an addition, with a single rounding. The fused multiplication and addition operations retain full accuracy in intermediate calculations. This behavior enables more accurate floating-point computations involving the accumulation of products, including dot products, matrix multiplication, and polynomial evaluation. The FMA instruction also enables efficient software implementations of exactly rounded division and square root, removing the need for a hardware division or square root unit.

A double-precision hardware FMA unit implements 64-bit addition, multiplication, conversions, and the FMA operation itself. The architecture of a

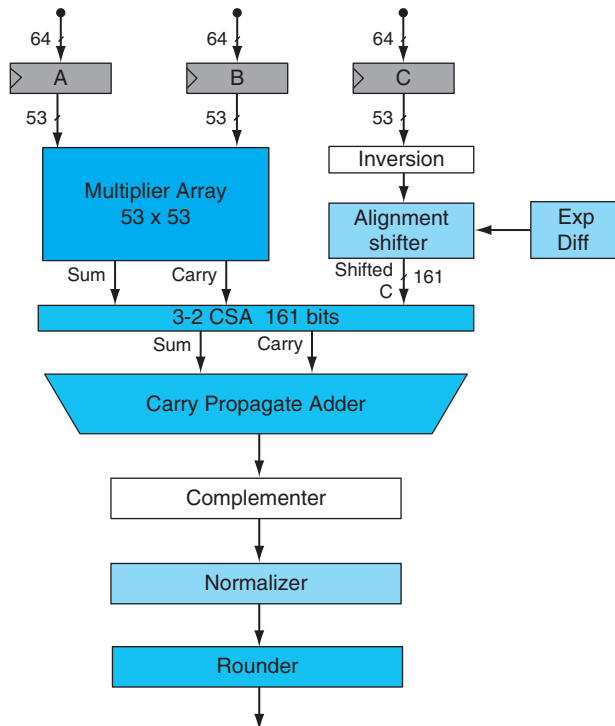

**FIGURE B.6.2 Double-precision fused-multiply-add (FMA) unit.** Hardware to implement floating-point  $A \times B + C$  for double precision.

double-precision FMA unit enables full-speed denormalized number support on both inputs and outputs. Figure B.6.2 shows a block diagram of an FMA unit.

As shown in Figure B.6.2, the significands of A and B are multiplied to form a 106-bit product, with the results left in carry-save form. In parallel, the 53-bit addend C is conditionally inverted and aligned to the 106-bit product. The sum and carry results of the 106-bit product are summed with the aligned addend through a 161-bit-wide *carry-save adder* (CSA). The carry-save output is then summed together in a carry-propagate adder to produce an unrounded result in nonredundant, two's complement form. The result is conditionally recomplemented, so as to return a result in sign-magnitude form. The complemented result is normalized, and then it is rounded to fit within the target format.

## B.7 Real Stuff: The NVIDIA GeForce 8800

The NVIDIA GeForce 8800 GPU, introduced in November 2006, is a unified vertex and pixel processor design that also supports parallel computing applications written in C using the CUDA parallel programming model. It is the first implementation of the Tesla unified graphics and computing architecture described in Section B.4 and in Lindholm et al. [2008]. A family of Tesla architecture GPUs addresses the different needs of laptops, desktops, workstations, and servers.

### Streaming Processor Array (SPA)

The GeForce 8800 GPU shown in Figure B.7.1 contains 128 *streaming processor* (SP) cores organized as 16 *streaming multiprocessors* (SMs). Two SMs share a texture unit in each *texture/processor cluster* (TPC). An array of eight TPCs makes up the *streaming processor array* (SPA), which executes all graphics shader programs and computing programs.

The host interface unit communicates with the host CPU via the PCI-Express bus, checks command consistency, and performs context switching. The input assembler collects geometric primitives (points, lines, triangles). The work distribution blocks dispatch vertices, pixels, and compute thread arrays to the TPCs in the SPA. The TPCs execute vertex and geometry shader programs and computing programs. Output geometric data are sent to the viewport/clip/setup/raster/zcull block to be rasterized into pixel fragments that are then redistributed back into the SPA to execute pixel shader programs. Shaded pixels are sent across the interconnection network for processing by the ROP units. The network also routes texture memory read requests from the SPA to DRAM and reads data from DRAM through a level-2 cache back to the SPA.

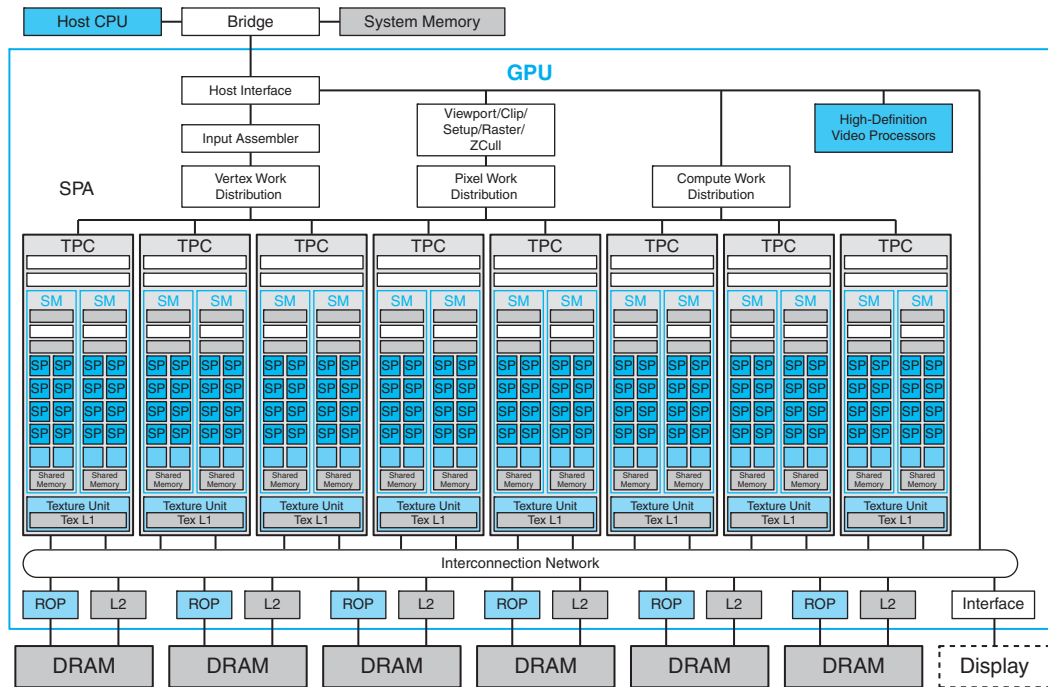

**FIGURE B.7.1 NVIDIA Tesla unified graphics and computing GPU architecture.** This GeForce 8800 has 128 *streaming processor* (SP) cores in 16 *streaming multiprocessors* (SMs), arranged in eight *texture/processor clusters* (TPCs). The processors connect with six 64-bit-wide DRAM partitions via an interconnection network. Other GPUs implementing the Tesla architecture vary the number of SP cores, SMs, DRAM partitions, and other units.

## Texture/Processor Cluster (TPC)

Each TPC contains a geometry controller, an SMC, two SMs, and a texture unit as shown in Figure B.7.2.

The geometry controller maps the logical graphics vertex pipeline into recirculation on the physical SMs by directing all primitive and vertex attribute and topology flow in the TPC.

The SMC controls multiple SMs, arbitrating the shared texture unit, load/store path, and I/O path. The SMC serves three graphics workloads simultaneously: vertex, geometry, and pixel.

The texture unit processes a texture instruction for one vertex, geometry, or pixel quad, or four compute threads per cycle. Texture instruction sources are texture coordinates, and the outputs are weighted samples, typically a four-component (RGBA) floating-point color. The texture unit is deeply pipelined. Although it contains a streaming cache to capture filtering locality, it streams hits mixed with misses without stalling.

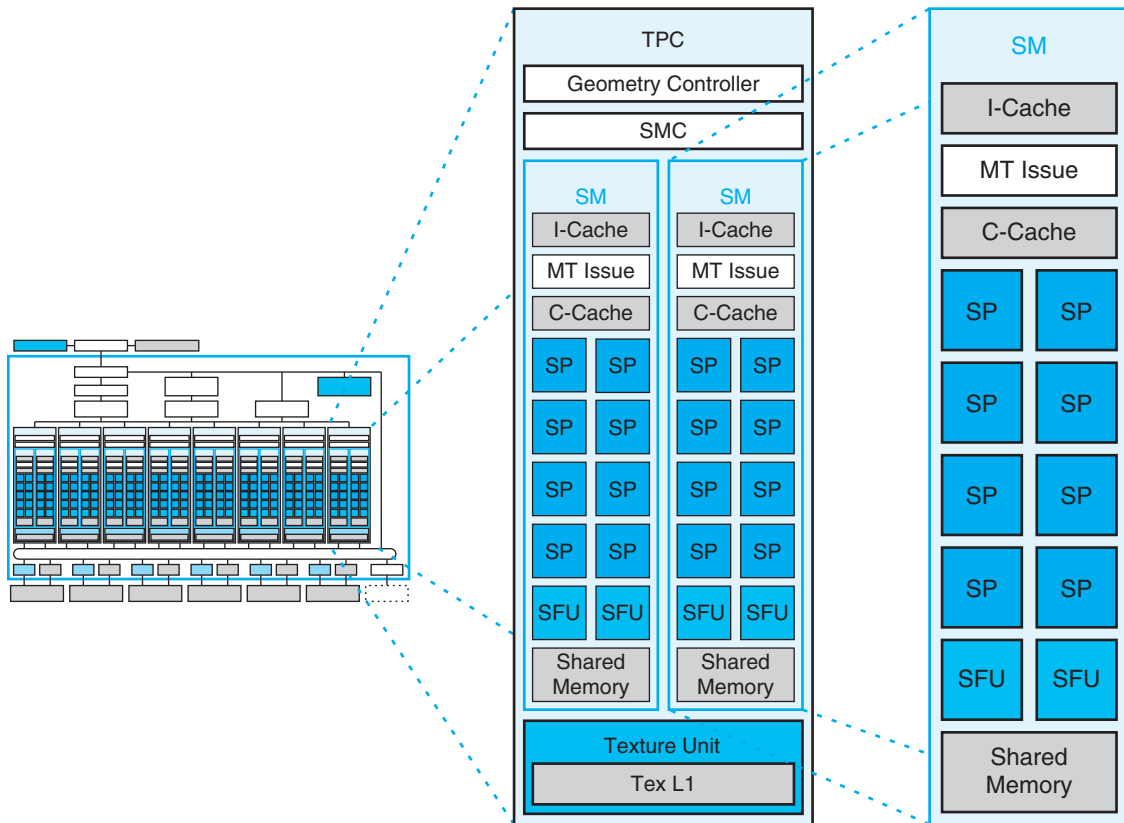

**FIGURE B.7.2** Texture/processor cluster (TPC) and a streaming multiprocessor (SM). Each SM has eight *streaming processor* (SP) cores, two SFUs, and a shared memory.

## Streaming Multiprocessor (SM)

The SM is a unified graphics and computing multiprocessor that executes vertex, geometry, and pixel-fragment shader programs and parallel computing programs. The SM consists of eight SP thread processor cores, two SFUs, a multithreaded instruction fetch and issue unit (MT issue), an instruction cache, a read-only constant cache, and a 16 KB read/write shared memory. It executes scalar instructions for individual threads.

The GeForce 8800 Ultra clocks the SP cores and SFUs at 1.5 GHz, for a peak of 36 GFLOPS per SM. To optimize power and area efficiency, some SM nondata path units operate at half the SP clock rate.



To efficiently execute hundreds of parallel threads while running several different programs, the SM is hardware multithreaded. It manages and executes up to 768 concurrent threads in hardware with zero scheduling overhead. Each thread has its own thread execution state and can execute an independent code path.

A warp consists of up to 32 threads of the same type—vertex, geometry, pixel, or compute. The SIMT design, previously described in Section B.4, shares the SM instruction fetch and issue unit efficiently across 32 threads but requires a full warp of active threads for full performance efficiency.

The SM schedules and executes multiple warp types concurrently. Each issue cycle, the scheduler selects one of the 24 warps to execute a SIMT warp instruction. An issued warp instruction executes as four sets of eight threads over four processor cycles. The SP and SFU units execute instructions independently, and by issuing instructions between them on alternate cycles, the scheduler can keep both fully occupied. A scoreboard qualifies each warp for issue each cycle. The instruction scheduler prioritizes all ready warps and selects the one with highest priority for issue. Prioritization considers warp type, instruction type, and “fairness” to all warps executing in the SM.

The SM executes *cooperative thread arrays* (CTAs) as multiple concurrent warps which access a shared memory region allocated dynamically for the CTA.

## Instruction Set

Threads execute scalar instructions, unlike previous GPU vector instruction architectures. Scalar instructions are simpler and compiler-friendly. Texture instructions remain vector-based, taking a source coordinate vector and returning a filtered color vector.

The register-based instruction set includes all the floating-point and integer arithmetic, transcendental, logical, flow control, memory load/store, and texture instructions listed in the PTX instruction table of Figure B.4.3. Memory load/store instructions use integer byte addressing with register-plus-offset address arithmetic. For computing, the load/store instructions access three read-write memory spaces: local memory for per-thread, private, temporary data; shared memory for low-latency per-CTA data shared by the threads of the CTA; and global memory for data shared by all threads. Computing programs use the fast barrier synchronization `bar.sync` instruction to synchronize threads within a CTA that communicate with each other via shared and global memory. The latest Tesla architecture GPUs implement PTX atomic memory operations, which facilitate parallel reductions and parallel data structure management.

## Streaming Processor (SP)

The multithreaded SP core is the primary thread processor, as introduced in Section B.4. Its register file provides 1024 scalar 32-bit registers for up to 96 threads (more threads than in the example SP of Section B.4). Its floating-point add and

multiply operations are compatible with the IEEE 754 standard for single-precision FP numbers, including *not-a-number* (NaN) and infinity. The add and multiply operations use IEEE round-to-nearest-even as the default rounding mode. The SP core also implements all of the 32-bit and 64-bit integer arithmetic, comparison, conversion, and logical PTX instructions in Figure B.4.3. The processor is fully pipelined, and latency is optimized to balance delay and area.

### **Special Function Unit (SFU)**

The SFU supports computation of both transcendental functions and planar attribute interpolation. As described in Section B.6, it uses quadratic interpolation based on enhanced minimax approximations to approximate the reciprocal, reciprocal square root,  $\log_2 x$ ,  $2^x$ , and sin/cos functions at one result per cycle. The SFU also supports pixel attribute interpolation such as color, depth, and texture coordinates at four samples per cycle.

### **Rasterization**

Geometry primitives from the SMs go in their original round-robin input order to the viewport/clip/setup/raster/zcull block. The viewport and clip units clip the primitives to the view frustum and to any enabled user clip planes, and then transform the vertices into screen (pixel) space.

Surviving primitives then go to the setup unit, which generates edge equations for the rasterizer. A coarse-rasterization stage generates all pixel tiles that are at least partially inside the primitive. The zcull unit maintains a hierarchical z surface, rejecting pixel tiles if they are conservatively known to be occluded by previously drawn pixels. The rejection rate is up to 256 pixels per clock. Pixels that survive zcull then go to a fine-rasterization stage that generates detailed coverage information and depth values.

The depth test and update can be performed ahead of the fragment shader, or after, depending on current state. The SMC assembles surviving pixels into warps to be processed by an SM running the current pixel shader. The SMC then sends surviving pixel and associated data to the ROP.

### **Raster Operations Processor (ROP) and Memory System**

Each ROP is paired with a specific memory partition. For each pixel fragment emitted by a pixel shader program, ROPs perform depth and stencil testing and updates, and in parallel, color blending and updates. Lossless color compression (up to 8:1) and depth compression (up to 8:1) are used to reduce DRAM bandwidth. Each ROP has a peak rate of four pixels per clock and supports 16-bit floating-point and 32-bit floating-point HDR formats. ROPs support double-rate-depth processing when color writes are disabled.

Antialiasing support includes up to  $16\times$  multisampling and supersampling. The *coverage-sampling antialiasing* (CSAA) algorithm computes and stores Boolean coverage at up to 16 samples and compresses redundant color, depth, and stencil information into the memory footprint and a bandwidth of four or eight samples for improved performance.

The DRAM memory data bus width is 384 pins, arranged in six independent partitions of 64 pins each. Each partition supports double-data-rate DDR2 and graphics-oriented GDDR3 protocols at up to 1.0 GHz, yielding a bandwidth of about 16 GB/s per partition, or 96 GB/s.

The memory controllers support a wide range of DRAM clock rates, protocols, device densities, and data bus widths. Texture and load/store requests can occur between any TPC and any memory partition, so an interconnection network routes requests and responses.

## Scalability

The Tesla unified architecture is designed for scalability. Varying the number of SMs, TPCs, ROPs, caches, and memory partitions provides the right balance for different performance and cost targets in GPU market segments. *Scalable link interconnect* (SLI) connects multiple GPUs, providing further scalability.

## Performance

The GeForce 8800 Ultra clocks the SP thread processor cores and SFUs at 1.5 GHz, for a theoretical operation peak of 576 GFLOPS. The GeForce 8800 GTX has a 1.35 GHz processor clock and a corresponding peak of 518 GFLOPS.

The following three sections compare the performance of a GeForce 8800 GPU with a multicore CPU on three different applications—dense linear algebra, fast Fourier transforms, and sorting. The GPU programs and libraries are compiled CUDA C code. The CPU code uses the single-precision multithreaded Intel MKL 10.0 library to leverage SSE instructions and multiple cores.

## Dense Linear Algebra Performance

Dense linear algebra computations are fundamental in many applications. Volkov and Demmel [2008] present GPU and CPU performance results for single-precision dense matrix-matrix multiplication (the SGEMM routine) and LU, QR, and Cholesky matrix factorizations. Figure B.7.3 compares GFLOPS rates on SGEMM dense matrix-matrix multiplication for a GeForce 8800 GTX GPU with a quad-core CPU. Figure B.7.4 compares GFLOPS rates on matrix factorization for a GPU with a quad-core CPU.

Because SGEMM matrix-matrix multiply and similar BLAS3 routines are the bulk of the work in matrix factorization, their performance sets an upper bound on factorization rate. As the matrix order increases beyond 200 to 400, the factorization

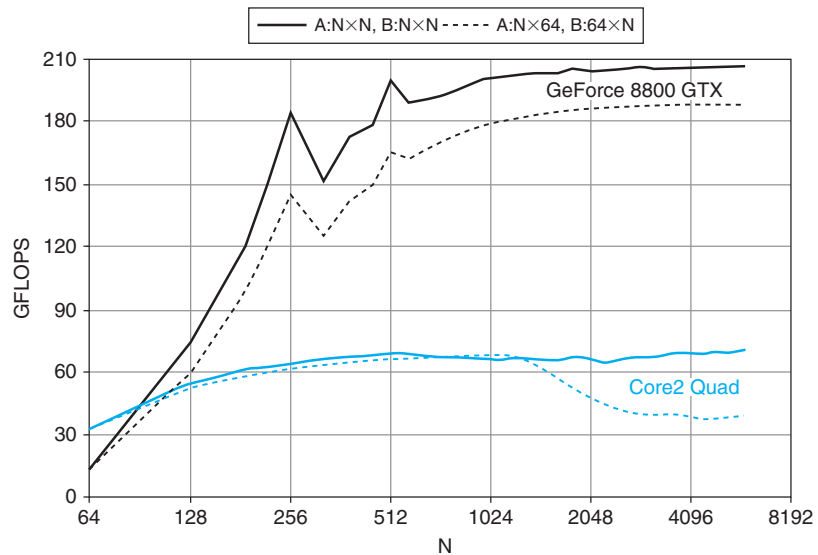

**FIGURE B.7.3 SGEMM dense matrix-matrix multiplication performance rates.** The graph shows single-precision GFLOPS rates achieved in multiplying square  $N \times N$  matrices (solid lines) and thin  $N \times 64$  and  $64 \times N$  matrices (dashed lines). Adapted from Figure 6 of Volkov and Demmel [2008]. The black lines are a 1.35 GHz GeForce 8800 GTX using Volkov's SGEMM code (now in NVIDIA CUBLAS 2.0) on matrices in GPU memory. The blue lines are a quad-core 2.4 GHz Intel Core2 Quad Q6600, 64-bit Linux, Intel MKL 10.0 on matrices in CPU memory.

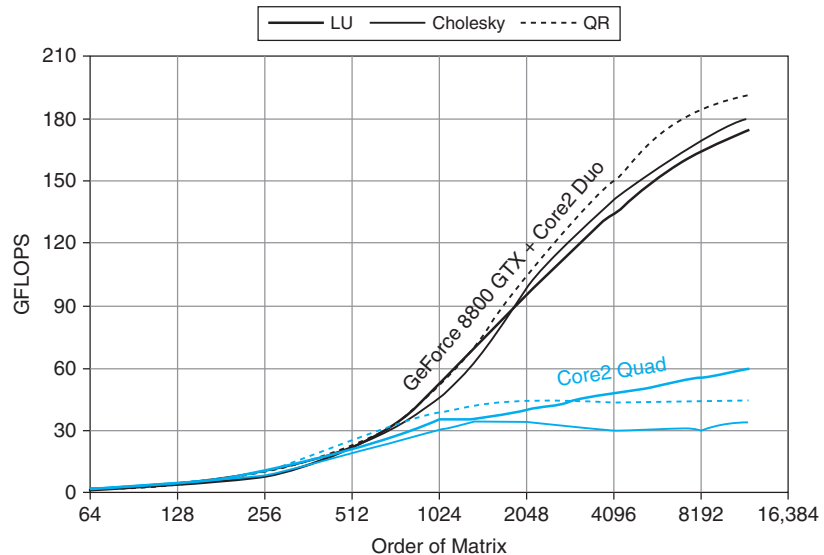

**FIGURE B.7.4 Dense matrix factorization performance rates.** The graph shows GFLOPS rates achieved in matrix factorizations using the GPU and using the CPU alone. Adapted from Figure 7 of Volkov and Demmel [2008]. The black lines are for a 1.35 GHz NVIDIA GeForce 8800 GTX, CUDA 1.1, Windows XP attached to a 2.67 GHz Intel Core2 Duo E6700 Windows XP, including all CPU-GPU data transfer times. The blue lines are for a quad-core 2.4 GHz Intel Core2 Quad Q6600, 64-bit Linux, Intel MKL 10.0.

problem becomes large enough that SGEMM can leverage the GPU parallelism and overcome the CPU–GPU system and copy overhead. Volkov’s SGEMM matrix-matrix multiply achieves 206 GFLOPS, about 60% of the GeForce 8800 GTX peak multiply-add rate, while the QR factorization reached 192 GFLOPS, about 4.3 times the quad-core CPU.

## FFT Performance

Fast Fourier Transforms (FFTs) are used in many applications. Large transforms and multidimensional transforms are partitioned into batches of smaller 1D transforms.

Figure B.7.5 compares the in-place 1D complex single-precision FFT performance of a 1.35 GHz GeForce 8800 GTX (dating from late 2006) with a 2.8 GHz quad-Core Intel Xeon E5462 series (code named “Harpertown,” dating from late 2007). CPU performance was measured using the Intel *Math Kernel Library* (MKL) 10.0 FFT with four threads. GPU performance was measured using the NVIDIA CUFFT 2.1 library and batched 1D radix-16 decimation-in-frequency FFTs. Both CPU and GPU throughput performance was measured using batched FFTs; batch size was  $2^{24}/n$ , where  $n$  is the transform size. Thus, the workload for every transform size was 128 MB. To determine GFLOPS rate, the number of operations per transform was taken as  $5n \log_2 n$ .

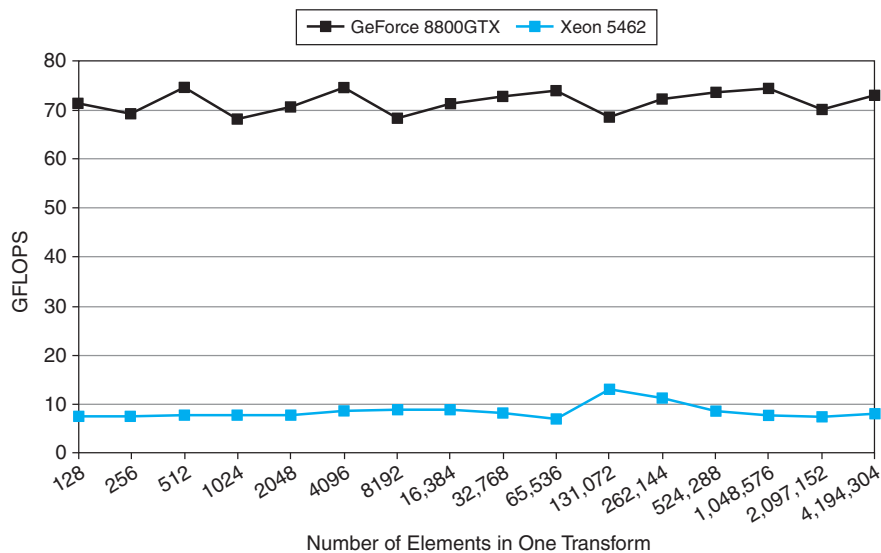

**FIGURE B.7.5 Fast Fourier transform throughput performance.** The graph compares the performance of batched one-dimensional in-place complex FFTs on a 1.35 GHz GeForce 8800 GTX with a quad-core 2.8 GHz Intel Xeon E5462 series (code named “Harpertown”), 6MB L2 Cache, 4GB Memory, 1600 FSB, Red Hat Linux, Intel MKL 10.0.

## Sorting Performance

In contrast to the applications just discussed, sort requires far more substantial coordination among parallel threads, and parallel scaling is correspondingly harder to obtain. Nevertheless, a variety of well-known sorting algorithms can be efficiently parallelized to run well on the GPU. Satish et al. [2008] detail the design of sorting algorithms in CUDA, and the results they report for radix sort are summarized below.

Figure B.7.6 compares the parallel sorting performance of a GeForce 8800 Ultra with an 8-core Intel Clovertown system, both of which date to early 2007. The CPU cores are distributed between two physical sockets. Each socket contains a multichip module with twin Core2 chips, and each chip has a 4MB L2 cache. All sorting routines were designed to sort key-value pairs where both keys and values are 32-bit integers. The primary algorithm being studied is radix sort, although the quicksort-based `parallel_sort()` procedure provided by Intel's Threading Building Blocks is also included for comparison. Of the two CPU-based radix sort codes, one was implemented using only the scalar instruction set and the other utilizes carefully hand-tuned assembly language routines that take advantage of the SSE2 SIMD vector instructions.

The graph itself shows the achieved sorting rate—defined as the number of elements sorted divided by the time to sort—for a range of sequence sizes. It is

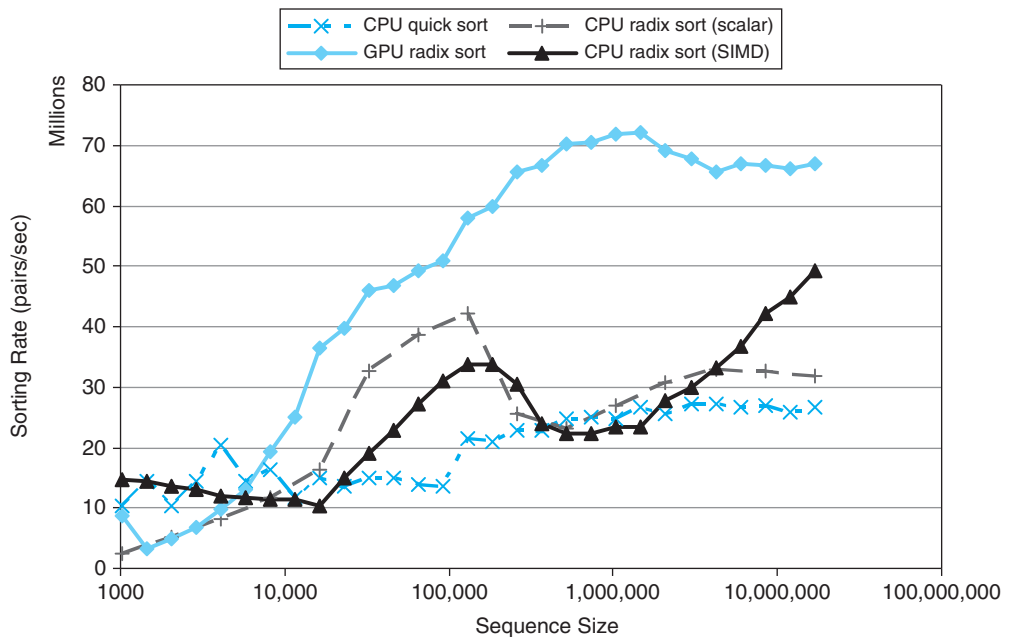

**FIGURE B.7.6 Parallel sorting performance.** This graph compares sorting rates for parallel radix sort implementations on a 1.5 GHz GeForce 8800 Ultra and an 8-core 2.33 GHz Intel Core2 Xeon E5345 system.

apparent from this graph that the GPU radix sort achieved the highest sorting rate for all sequences of 8K-elements and larger. In this range, it is on average 2.6 times faster than the quicksort-based routine and roughly two times faster than the radix sort routines, all of which were using the eight available CPU cores. The CPU radix sort performance varies widely, likely due to poor cache locality of its global permutations.

## B.8

## Real Stuff: Mapping Applications to GPUs

The advent of multicore CPUs and manycore GPUs means that mainstream processor chips are now parallel systems. Furthermore, their parallelism continues to scale with Moore's law. The challenge is to develop mainstream visual computing and high-performance computing applications that transparently scale their parallelism to leverage the increasing number of processor cores, much as 3D graphics applications transparently scale their parallelism to GPUs with widely varying numbers of cores.

This section presents examples of mapping scalable parallel computing applications to the GPU using CUDA.

### Sparse Matrices

A wide variety of parallel algorithms can be written in CUDA in a fairly straightforward manner, even when the data structures involved are not simple regular grids. *Sparse matrix-vector multiplication* (SpMV) is a good example of an important numerical building block that can be parallelized quite directly using the abstractions provided by CUDA. The kernels we discuss below, when combined with the provided CUBLAS vector routines, make writing iterative solvers such as the conjugate gradient method straightforward.

A sparse  $n \times n$  matrix is one in which the number of nonzero entries  $m$  is only a small fraction of the total. Sparse matrix representations seek to store only the nonzero elements of a matrix. Since it is fairly typical that a sparse  $n \times n$  matrix will contain only  $m = O(n)$  nonzero elements, this represents a substantial saving in storage space and processing time.

One of the most common representations for general unstructured sparse matrices is the *compressed sparse row* (CSR) representation. The  $m$  nonzero elements of the matrix  $A$  are stored in row-major order in an array  $A_v$ . A second array  $A_j$  records the corresponding column index for each entry of  $A_v$ . Finally, an array  $A_p$  of  $n + 1$  elements records the extent of each row in the previous arrays; the entries for row  $i$  in  $A_j$  and  $A_v$  extend from index  $A_p[i]$  up to, but not including, index  $A_p[i + 1]$ . This implies that  $A_p[0]$  will always be 0 and  $A_p[n]$  will always be the number of nonzero elements in the matrix. Figure B.8.1 shows an example of the CSR representation of a simple matrix.



$$A = \begin{bmatrix} 3 & 0 & 1 & 0 \\ 0 & 0 & 0 & 0 \\ 0 & 2 & 4 & 1 \\ 1 & 0 & 0 & 1 \end{bmatrix}$$

a. Sample matrix  $A$ 

$$\begin{array}{l} \text{Row 0} \quad \text{Row 2} \quad \text{Row 3} \\ Av[7] = \{ \textcircled{3} \ \textcircled{1} \ \textcircled{2} \ \textcircled{4} \ \textcircled{1} \ \textcircled{1} \ \textcircled{1} \} \\ Aj[7] = \{ \textcircled{0} \ \textcircled{2} \ \textcircled{1} \ \textcircled{2} \ \textcircled{3} \ \textcircled{0} \ \textcircled{3} \} \\ \hline Ap[5] = \{ 0 \ 2 \ 2 \ 5 \ 7 \} \end{array}$$

b. CSR representation of matrix

**FIGURE B.8.1 Compressed sparse row (CSR) matrix.**

```
float multiply_row(unsigned int rowsize,
                 unsigned int *Aj, // column indices for row
                 float *Av,       // nonzero entries for row
                 float *x)       // the RHS vector
{
    float sum = 0;

    for(unsigned int column=0; column<rowsize; ++column)
        sum += Av[column] * x[Aj[column]];

    return sum;
}
```

**FIGURE B.8.2 Serial C code for a single row of sparse matrix-vector multiply.**

Given a matrix  $A$  in CSR form and a vector  $x$ , we can compute a single row of the product  $y = Ax$  using the `multiply_row()` procedure shown in Figure B.8.2. Computing the full product is then simply a matter of looping over all rows and computing the result for that row using `multiply_row()`, as in the serial C code shown in Figure B.8.3.

This algorithm can be translated into a parallel CUDA kernel quite easily. We simply spread the loop in `csmul_serial()` over many parallel threads. Each thread will compute exactly one row of the output vector  $y$ . The code for this kernel is shown in Figure B.8.4. Note that it looks extremely similar to the serial loop used in the `csmul_serial()` procedure. There are really only two points of difference. First, the row index for each thread is computed from the block and thread indices assigned to each thread, eliminating the for-loop. Second, we have a conditional that only evaluates a row product if the row index is within the bounds of the matrix (this is necessary since the number of rows  $n$  need not be a multiple of the block size used in launching the kernel).

---

```

void csrmmul_serial(unsigned int *Ap, unsigned int *Aj,
                   float *Av, unsigned int num_rows,
                   float *x, float *y)
{
    for(unsigned int row=0; row<num_rows; ++row)
    {
        unsigned int row_begin = Ap[row];
        unsigned int row_end   = Ap[row+1];

        y[row] = multiply_row(row_end-row_begin, Aj+row_begin,
                              Av+row_begin, x);
    }
}

```

---

**FIGURE B.8.3** Serial code for sparse matrix-vector multiply.

```

__global__
void csrmmul_kernel(unsigned int *Ap, unsigned int *Aj,
                   float *Av, unsigned int num_rows,
                   float *x, float *y)
{
    unsigned int row = blockIdx.x*blockDim.x + threadIdx.x;

    if( row<num_rows )
    {
        unsigned int row_begin = Ap[row];
        unsigned int row_end   = Ap[row+1];

        y[row] = multiply_row(row_end-row_begin, Aj+row_begin,
                              Av+row_begin, x);
    }
}

```

---

**FIGURE B.8.4** CUDA version of sparse matrix-vector multiply.

Assuming that the matrix data structures have already been copied to the GPU device memory, launching this kernel will look like:

```

unsigned int blocksize = 128; // or any size up to 512
unsigned int nblocks   = (num_rows + blocksize - 1) / blocksize;
csrmmul_kernel<<<nblocks,blocksize>>>(Ap, Aj, Av, num_rows, x, y);

```

The pattern that we see here is a very common one. The original serial algorithm is a loop whose iterations are independent of each other. Such loops can be parallelized quite easily by simply assigning one or more iterations of the loop to each parallel thread. The programming model provided by CUDA makes expressing this type of parallelism particularly straightforward.

This general strategy of decomposing computations into blocks of independent work, and more specifically breaking up independent loop iterations, is not unique to CUDA. This is a common approach used in one form or another by various parallel programming systems, including OpenMP and Intel's Threading Building Blocks.

### Caching in Shared Memory

The SpMV algorithms outlined above are fairly simplistic. There are a number of optimizations that can be made in both the CPU and GPU codes that can improve performance, including loop unrolling, matrix reordering, and register blocking. The parallel kernels can also be reimplemented in terms of data parallel *scan* operations presented by Sengupta et al. [2007].

One of the important architectural features exposed by CUDA is the presence of the per-block shared memory, a small on-chip memory with very low latency. Taking advantage of this memory can deliver substantial performance improvements. One common way of doing this is to use shared memory as a software-managed cache to hold frequently reused data. Modifications using shared memory are shown in Figure B.8.5.

In the context of sparse matrix multiplication, we observe that several rows of  $A$  may use a particular array element  $x[i]$ . In many common cases, and particularly when the matrix has been reordered, the rows using  $x[i]$  will be rows near row  $i$ . We can therefore implement a simple caching scheme and expect to achieve some performance benefit. The block of threads processing rows  $i$  through  $j$  will load  $x[i]$  through  $x[j]$  into its shared memory. We will unroll the `multiply_row()` loop and fetch elements of  $x$  from the cache whenever possible. The resulting code is shown in Figure B.8.5. Shared memory can also be used to make other optimizations, such as fetching  $A_p[\text{row}+1]$  from an adjacent thread rather than refetching it from memory.

Because the Tesla architecture provides an explicitly managed on-chip shared memory, rather than an implicitly active hardware cache, it is fairly common to add this sort of optimization. Although this can impose some additional development burden on the programmer, it is relatively minor, and the potential performance benefits can be substantial. In the example shown above, even this fairly simple use of shared memory returns a roughly 20% performance improvement on representative matrices derived from 3D surface meshes. The availability of an explicitly managed memory in lieu of an implicit cache also has the advantage that caching and prefetching policies can be specifically tailored to the application needs.

```

__global__
void csrmul_cached(unsigned int *Ap, unsigned int *Aj,
                  float *Av, unsigned int num_rows,
                  const float *x, float *y)
{
    // Cache the rows of x[] corresponding to this block.
    __shared__ float cache[blocksize];

    unsigned int block_begin = blockIdx.x * blockDim.x;
    unsigned int block_end   = block_begin + blockDim.x;
    unsigned int row         = block_begin + threadIdx.x;

    // Fetch and cache our window of x[].
    if( row < num_rows ) cache[threadIdx.x] = x[row];
    __syncthreads();

    if( row < num_rows )
    {
        unsigned int row_begin = Ap[row];
        unsigned int row_end   = Ap[row+1];
        float sum = 0, x_j;

        for(unsigned int col=row_begin; col < row_end; ++col)
        {
            unsigned int j = Aj[col];

            // Fetch x_j from our cache when possible
            if( j >= block_begin && j < block_end )
                x_j = cache[j-block_begin];
            else
                x_j = x[j];

            sum += Av[col] * x_j;
        }

        y[row] = sum;
    }
}

```

---

**FIGURE B.8.5** Shared memory version of sparse matrix-vector multiply.

These are fairly simple kernels whose purpose is to illustrate basic techniques in writing CUDA programs, rather than how to achieve maximal performance. Numerous possible avenues for optimization are available, several of which are explored by Williams et al. [2007] on a handful of different multicore architectures. Nevertheless, it is still instructive to examine the comparative performance of even these simplistic kernels. On a 2 GHz Intel Core2 Xeon E5335 processor, the `csmul_serial()` kernel runs at roughly 202 million nonzeros processed per second, for a collection of Laplacian matrices derived from 3D triangulated surface meshes. Parallelizing this kernel with the `parallel_for` construct provided by Intel's Threading Building Blocks produces parallel speed-ups of 2.0, 2.1, and 2.3 running on two, four, and eight cores of the machine, respectively. On a GeForce 8800 Ultra, the `csmul_kernel()` and `csmul_cached()` kernels achieve processing rates of roughly 772 and 920 million nonzeros per second, corresponding to parallel speed-ups of 3.8 and 4.6 times over the serial performance of a single CPU core.

## Scan and Reduction

Parallel *scan*, also known as parallel *prefix sum*, is one of the most important building blocks for data-parallel algorithms [Blelloch, 1990]. Given a sequence  $a$  of  $n$  elements:

$$[a_0, a_1, \dots, a_{n-1}]$$

and a binary associative operator  $\oplus$ , the scan function computes the sequence:

$$\text{scan}(a, \oplus) = [a_0, (a_0 \oplus a_1), \dots, (a_0 \oplus a_1 \oplus \dots \oplus a_{n-1})]$$

As an example, if we take  $\oplus$  to be the usual addition operator, then applying scan to the input array

$$a = [3 \ 1 \ 7 \ 0 \ 4 \ 1 \ 6 \ 3]$$

will produce the sequence of partial sums:

$$\text{scan}(a, +) = [3 \ 4 \ 11 \ 11 \ 15 \ 16 \ 22 \ 25]$$

This scan operator is an *inclusive* scan, in the sense that element  $i$  of the output sequence incorporates element  $a_i$  of the input. Incorporating only previous elements would yield an *exclusive* scan operator, also known as a *prefix-sum* operation.

The serial implementation of this operation is extremely simple. It is simply a loop that iterates once over the entire sequence, as shown in Figure B.8.6.

At first glance, it might appear that this operation is inherently serial. However, it can actually be implemented in parallel efficiently. The key observation is that

---

```

template<class T>
__host__ T plus_scan(T *x, unsigned int n)
{
    for(unsigned int i=1; i<n; ++i)
        x[i] = x[i-1] + x[i];
}

```

---

**FIGURE B.8.6** Template for serial plus-scan.

```

template<class T>
__device__ T plus_scan(T *x)
{
    unsigned int i = threadIdx.x;
    unsigned int n = blockDim.x;

    for(unsigned int offset=1; offset<n; offset *= 2)
    {
        T t;

        if(i>=offset) t = x[i-offset];
        __syncthreads();

        if(i>=offset) x[i] = t + x[i];
        __syncthreads();
    }
    return x[i];
}

```

---

**FIGURE B.8.7** CUDA template for parallel plus-scan.

because addition is associative, we are free to change the order in which elements are added together. For instance, we can imagine adding pairs of consecutive elements in parallel, and then adding these partial sums, and so on.

One simple scheme for doing this is from Hillis and Steele [1989]. An implementation of their algorithm in CUDA is shown in Figure B.8.7. It assumes that the input array  $x[ ]$  contains exactly one element per thread of the thread block. It performs  $\log_2 n$  iterations of a loop collecting partial sums together.

To understand the action of this loop, consider Figure B.8.8, which illustrates the simple case for  $n = 8$  threads and elements. Each level of the diagram represents one step of the loop. The lines indicate the location from which the data are being fetched. For each element of the output (i.e., the final row of the diagram) we are building a summation tree over the input elements. The edges highlighted in blue show the form of this summation tree for the final element. The leaves of this tree are all the initial elements. Tracing back from any output element shows that it incorporates all input values up to and including itself.

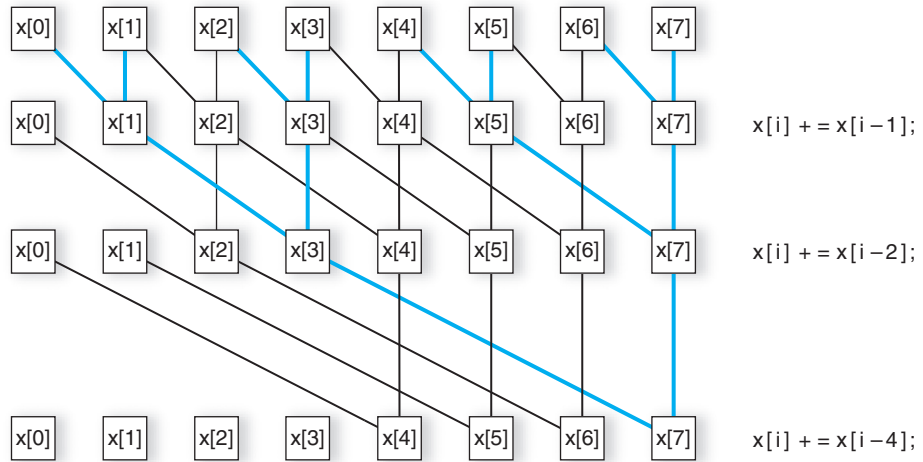

**FIGURE B.8.8** Tree-based parallel scan data references.

While simple, this algorithm is not as efficient as we would like. Examining the serial implementation, we see that it performs  $O(n)$  additions. The parallel implementation, in contrast, performs  $O(n \log n)$  additions. For this reason, it is not *work efficient*, since it does more work than the serial implementation to compute the same result. Fortunately, there are other techniques for implementing scan that are work-efficient. Details on more efficient implementation techniques and the extension of this per-block procedure to multiblock arrays are provided by Sengupta et al. [2007].

In some instances, we may only be interested in computing the sum of all elements in an array, rather than the sequence of all prefix sums returned by `scan`. This is the *parallel reduction* problem. We could simply use a scan algorithm to perform this computation, but reduction can generally be implemented more efficiently than scan.

Figure B.8.9 shows the code for computing a reduction using addition. In this example, each thread simply loads one element of the input sequence (i.e., it initially sums a subsequence of length 1). At the end of the reduction, we want thread 0 to hold the sum of all elements initially loaded by the threads of its block. The loop in this kernel implicitly builds a summation tree over the input elements, much like the scan algorithm above.

At the end of this loop, thread 0 holds the sum of all the values loaded by this block. If we want the final value of the location pointed to by `total` to contain the total of all elements in the array, we must combine the partial sums of all the blocks in the grid. One strategy to do this would be to have each block write its partial sum into a second array and then launch the reduction kernel again, repeating the process until we had reduced the sequence to a single value. A more attractive alternative supported by the Tesla GPU architecture is to use the `atomicAdd()` primitive, an efficient atomic



```

__global__
void plus_reduce(int *input, unsigned int N, int *total)
{
    unsigned int tid = threadIdx.x;
    unsigned int i    = blockIdx.x*blockDim.x + threadIdx.x;

    // Each block loads its elements into shared memory, padding
    // with 0 if N is not a multiple of blocksize
    __shared__ int x[blocksize];
    x[tid] = (i<N) ? input[i] : 0;
    __syncthreads();

    // Every thread now holds 1 input value in x[]
    //
    // Build summation tree over elements.
    for(int s=blockDim.x/2; s>0; s=s/2)
    {
        if(tid < s) x[tid] += x[tid + s];
        __syncthreads();
    }

    // Thread 0 now holds the sum of all input values
    // to this block. Have it add that sum to the running total
    if( tid == 0 ) atomicAdd(total, x[tid]);
}

```

---

**FIGURE B.8.9** CUDA implementation of plus-reduction.

read-modify-write primitive supported by the memory subsystem. This eliminates the need for additional temporary arrays and repeated kernel launches.

Parallel reduction is an essential primitive for parallel programming and highlights the importance of per-block shared memory and low-cost barriers in making cooperation among threads efficient. This degree of data shuffling among threads would be prohibitively expensive if done in off-chip global memory.

## Radix Sort

One important application of scan primitives is in the implementation of sorting routines. The code in Figure B.8.10 implements a radix sort of integers across a single thread block. It accepts as input an array `values` containing one 32-bit integer for each thread of the block. For efficiency, this array should be stored in per-block shared memory, but this is not required for the sort to behave correctly.

This is a fairly simple implementation of radix sort. It assumes the availability of a procedure `partition_by_bit()` that will partition the given array such that

---

```

__device__ void radix_sort(unsigned int *values)
{
    for(int bit=0; bit<32; ++bit)
    {
        partition_by_bit(values, bit);
        __syncthreads();
    }
}

```

---

**FIGURE B.8.10** CUDA code for radix sort.

```

__device__ void partition_by_bit(unsigned int *values,
                                unsigned int bit)
{
    unsigned int i    = threadIdx.x;
    unsigned int size = blockDim.x;
    unsigned int x_i  = values[i];
    unsigned int p_i  = (x_i >> bit) & 1;

    values[i] = p_i;
    __syncthreads();

    // Compute number of T bits up to and including p_i.
    // Record the total number of F bits as well.
    unsigned int T_before = plus_scan(values);
    unsigned int T_total  = values[size-1];
    unsigned int F_total  = size - T_total;
    __syncthreads();

    // Write every x_i to its proper place
    if( p_i )
        values[T_before-1 + F_total] = x_i;
    else
        values[i - T_before] = x_i;
}

```

---

**FIGURE B.8.11** CUDA code to partition data on a bit-by-bit basis, as part of radix sort.

all values with a 0 in the designated bit will come before all values with a 1 in that bit. To produce the correct output, this partitioning must be stable.

Implementing the partitioning procedure is a simple application of scan. Thread  $i$  holds the value  $x_i$  and must calculate the correct output index at which to write this value. To do so, it needs to calculate (1) the number of threads  $j < i$  for which the designated bit is 1 and (2) the total number of bits for which the designated bit is 0. The CUDA code for `partition_by_bit()` is shown in Figure B.8.11.

A similar strategy can be applied for implementing a radix sort kernel that sorts an array of large length, rather than just a one-block array. The fundamental step remains the scan procedure, although when the computation is partitioned across multiple kernels, we must double-buffer the array of values rather than doing the partitioning in place. Details on performing radix sorts on large arrays efficiently are provided by Satish et al. [2008].

## N-Body Applications on a GPU<sup>1</sup>

Nyland et al. [2007] describe a simple yet useful computational kernel with excellent GPU performance—the *all-pairs N-body* algorithm. It is a time-consuming component of many scientific applications. N-body simulations calculate the evolution of a system of bodies in which each body continuously interacts with every other body. One example is an astrophysical simulation in which each body represents an individual star, and the bodies gravitationally attract each other. Other examples are protein folding, where N-body simulation is used to calculate electrostatic and van der Waals forces; turbulent fluid flow simulation; and global illumination in computer graphics.

The all-pairs N-body algorithm calculates the total force on each body in the system by computing each pair-wise force in the system, summing for each body. Many scientists consider this method to be the most accurate, with the only loss of precision coming from the floating-point hardware operations. The drawback is its  $O(n^2)$  computational complexity, which is far too large for systems with more than 10 bodies. To overcome this high cost, several simplifications have been proposed to yield  $O(n \log n)$  and  $O(n)$  algorithms; examples are the Barnes-Hut algorithm, the Fast Multipole Method and Particle-Mesh-Ewald summation. All of the *fast* methods still rely on the all-pairs method as a kernel for accurate computation of short-range forces; thus it continues to be important.

### N-Body Mathematics

For gravitational simulation, calculate the body-body force using elementary physics. Between two bodies indexed by  $i$  and  $j$ , the 3D force vector is:

$$\mathbf{f}_{ij} = G \frac{m_i m_j}{\|\mathbf{r}_{ij}\|^2} \times \frac{\mathbf{r}_{ij}}{\|\mathbf{r}_{ij}\|}$$

The force magnitude is calculated in the left term, while the direction is computed in the right (unit vector pointing from one body to the other).

Given a list of interacting bodies (an entire system or a subset), the calculation is simple: for all pairs of interactions, compute the force and sum for each body. Once the total forces are calculated, they are used to update each body's position and velocity, based on the previous position and velocity. The calculation of the forces has complexity  $O(n^2)$ , while the update is  $O(n)$ .

<sup>1</sup> Adapted from Nyland et al. [2007], "Fast N-Body Simulation with CUDA," Chapter 31 of *GPU Gems 3*.

The serial force-calculation code uses two nested for-loops iterating over pairs of bodies. The outer loop selects the body for which the total force is being calculated, and the inner loop iterates over all the bodies. The inner loop calls a function that computes the pair-wise force, then adds the force into a running sum.

To compute the forces in parallel, we assign one thread to each body, since the calculation of force on each body is independent of the calculation on all other bodies. Once all of the forces are computed, the positions and velocities of the bodies can be updated.

The code for the serial and parallel versions is shown in Figure B.8.12 and Figure B.8.13. The serial version has two nested for-loops. The conversion to CUDA, like many other examples, converts the serial outer loop to a per-thread kernel where each thread computes the total force on a single body. The CUDA kernel computes a global thread ID for each thread, replacing the iterator variable of the serial outer loop. Both kernels finish by storing the total acceleration in a global array used to compute the new position and velocity values in a subsequent step. The outer loop is replaced by a CUDA kernel grid that launches  $N$  threads, one for each body.

```
void accel_on_all_bodies()
{
    int i, j;
    float3 acc(0.0f, 0.0f, 0.0f);

    for (i = 0; i < N; i++) {
        for (j = 0; j < N; j++) {
            acc = body_body_interaction(acc, body[i], body[j]);
        }
        accel[i] = acc;
    }
}
```

**FIGURE B.8.12** Serial code to compute all pair-wise forces on  $N$  bodies.

```
__global__ void accel_on_one_body()
{
    int i = threadIdx.x + blockDim.x * blockIdx.x;
    int j;
    float3 acc(0.0f, 0.0f, 0.0f);

    for (j = 0; j < N; j++) {
        acc = body_body_interaction(acc, body[i], body[j]);
    }
    accel[i] = acc;
}
```

**FIGURE B.8.13** CUDA thread code to compute the total force on a single body.

### Optimization for GPU Execution

The CUDA code shown is functionally correct, but is not efficient, as it ignores key architectural features. Better performance can be achieved with three main optimizations. First, shared memory can be used to avoid identical memory reads between threads. Second, using multiple threads per body improves performance for small values of  $N$ . Third, loop unrolling reduces loop overhead.

### Using Shared Memory

Shared memory can hold a subset of body positions, much like a cache, eliminating redundant global memory requests between threads. We optimize the code shown above to have each of  $p$  threads in a thread-block load *one* position into shared memory (for a total of  $p$  positions). Once all the threads have loaded a value into shared memory, ensured by `__syncthreads()`, each thread can then perform  $p$  interactions (using the data in shared memory). This is repeated  $N/p$  times to complete the force calculation for each body, which reduces the number of requests to memory by a factor of  $p$  (typically in the range 32–128).

The function called `accel_on_one_body()` requires a few changes to support this optimization. The modified code is shown in Figure B.8.14.

```

__shared__ float4 shPosition[256];
...
__global__ void accel_on_one_body()
{
    int i = threadIdx.x + blockDim.x * blockIdx.x;
    int j, k;
    int p = blockDim.x;
    float3 acc(0.0f, 0.0f, 0.0f);
    float4 myBody = body[i];

    for (j = 0; j < N; j += p) { // Outer loops jumps by p each time
        shPosition[threadIdx.x] = body[j+threadIdx.x];
        __syncthreads();
        for (k = 0; k < p; k++) { // Inner loop accesses p positions
            acc = body_body_interaction(acc, myBody, shPosition[k]);
        }
        __syncthreads();
    }
    accel[i] = acc;
}

```

**FIGURE B.8.14** CUDA code to compute the total force on each body, using shared memory to improve performance.

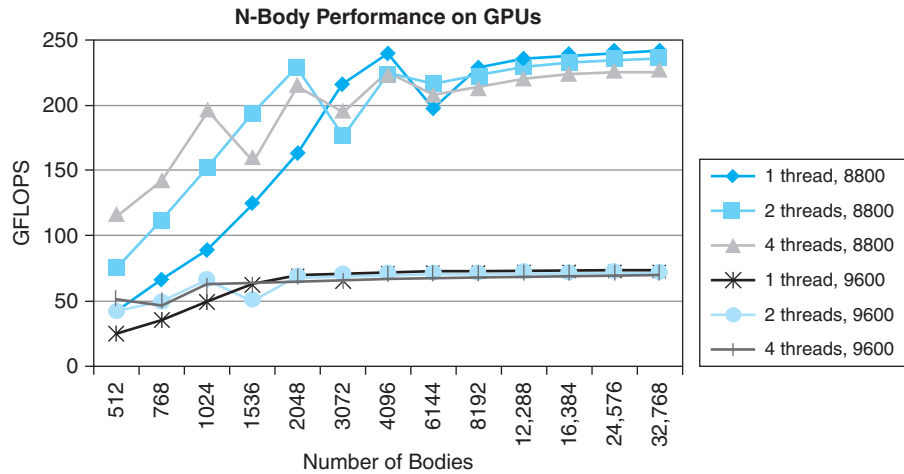

**FIGURE B.8.15 Performance measurements of the N-body application on a GeForce 8800 GTX and a GeForce 9600.** The 8800 has 128 stream processors at 1.35 GHz, while the 9600 has 64 at 0.80 GHz (about 30% of the 8800). The peak performance is 242 GFLOPS. For a GPU with more processors, the problem needs to be bigger to achieve full performance (the 9600 peak is around 2048 bodies, while the 8800 doesn't reach its peak until 16,384 bodies). For small  $N$ , more than one thread per body can significantly improve performance, but eventually incurs a performance penalty as  $N$  grows.

The loop that formerly iterated over all bodies now jumps by the block dimension  $p$ . Each iteration of the outer loop loads  $p$  successive positions into shared memory (one position per thread). The threads synchronize, and then  $p$  force calculations are computed by each thread. A second synchronization is required to ensure that new values are not loaded into shared memory prior to all threads completing the force calculations with the current data.

Using shared memory reduces the memory bandwidth required to less than 10% of the total bandwidth that the GPU can sustain (using less than 5 GB/s). This optimization keeps the application busy performing computation rather than waiting on memory accesses, as it would have done without the use of shared memory. The performance for varying values of  $N$  is shown in Figure B.8.15.

### Using Multiple Threads per Body

Figure B.8.15 shows performance degradation for problems with small values of  $N$  ( $N < 4096$ ) on the GeForce 8800 GTX. Many research efforts that rely on N-body calculations focus on small  $N$  (for long simulation times), making it a target of our optimization efforts. Our presumption to explain the lower performance was that there was simply not enough work to keep the GPU busy when  $N$  is small. The solution is to allocate more threads per body. We change the thread-block dimensions from  $(p, 1, 1)$  to  $(p, q, 1)$ , where  $q$  threads divide the work of a single body into equal parts. By allocating the additional threads within the same thread block, partial results can be stored in shared memory. When all the force calculations are

done, the  $q$  partial results can be collected and summed to compute the final result. Using two or four threads per body leads to large improvements for small  $N$ .

As an example, the performance on the 8800 GTX jumps by 110% when  $N = 1024$  (one thread achieves 90 GFLOPS, where four achieve 190 GFLOPS). Performance degrades slightly on large  $N$ , so we only use this optimization for  $N$  smaller than 4096. The performance increases are shown in Figure B.8.15 for a GPU with 128 processors and a smaller GPU with 64 processors clocked at two-thirds the speed.

### Performance Comparison

The performance of the N-body code is shown in Figure B.8.15 and Figure B.8.16. In Figure B.8.15, performance of high- and medium-performance GPUs is shown, along with the performance improvements achieved by using multiple threads per body. The performance on the faster GPU ranges from 90 to just under 250 GFLOPS.

Figure B.8.16 shows nearly identical code (C++ versus CUDA) running on Intel Core2 CPUs. The CPU performance is about 1% of the GPU, in the range of 0.2 to 2 GFLOPS, remaining nearly constant over the wide range of problem sizes.

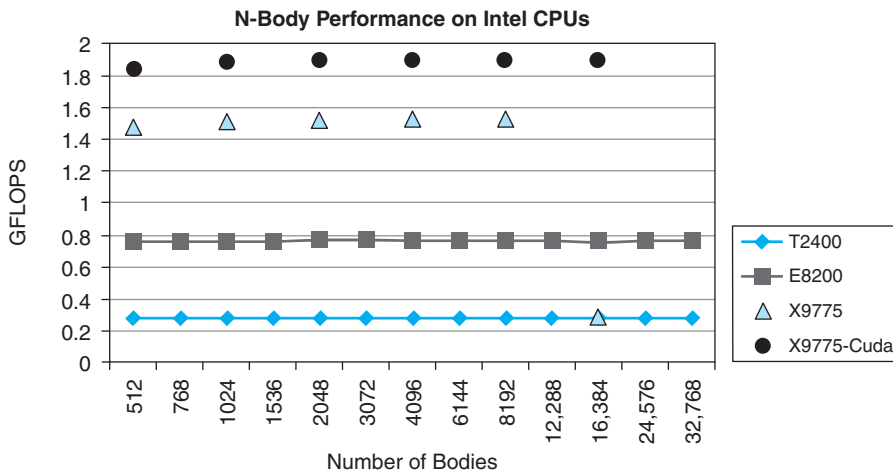

**FIGURE B.8.16 Performance measurements on the N-body code on a CPU.** The graph shows single precision N-body performance using Intel Core2 CPUs, denoted by their CPU model number. Note the dramatic reduction in GFLOPS performance (shown in GFLOPS on the y-axis), demonstrating how much faster the GPU is compared to the CPU. The performance on the CPU is generally independent of problem size, except for an anomalously low performance when  $N=16,384$  on the X9775 CPU. The graph also shows the results of running the CUDA version of the code (using the CUDA-for-CPU compiler) on a single CPU core, where it outperforms the C++ code by 24%. As a programming language, CUDA exposes parallelism and locality that a compiler can exploit. The Intel CPUs are a 3.2 GHz Extreme X9775 (code named “Penryn”), a 2.66 GHz E8200 (code named “Wolfdale”), a desktop, pre-Penryn CPU, and a 1.83 GHz T2400 (code named “Yonah”), a 2007 laptop CPU. The Penryn version of the Core 2 architecture is particularly interesting for N-body calculations with its 4-bit divider, allowing division and square root operations to execute four times faster than previous Intel CPUs.



The graph also shows the results of compiling the CUDA version of the code for a CPU, where the performance improves by 24%. CUDA, as a programming language, exposes parallelism, allowing the compiler to make better use of the SSE vector unit on a single core. The CUDA version of the N-body code naturally maps to multicore CPUs as well (with grids of blocks), where it achieves nearly perfect scaling on an eight-core system with  $N = 4096$  (ratios of 2.0, 3.97, and 7.94 on two, four, and eight cores, respectively).

## Results

With a modest effort, we developed a computational kernel that improves GPU performance over multicore CPUs by a factor of up to 157. Execution time for the N-body code running on a recent CPU from Intel (Penryn X9775 at 3.2 GHz, single core) took more than 3 seconds per frame to run the same code that runs at a 44 Hz frame rate on a GeForce 8800 GPU. On pre-Penryn CPUs, the code requires 6–16 seconds, and on older Core2 processors and Pentium IV processor, the time is about 25 seconds. We must divide the apparent increase in performance in half, as the CPU requires only half as many calculations to compute the same result (using the optimization that the forces on a pair of bodies are equal in strength and opposite in direction).

How can the GPU speed up the code by such a large amount? The answer requires inspecting architectural details. The pair-wise force calculation requires 20 floating-point operations, comprised mostly of addition and multiplication instructions (some of which can be combined using a multiply-add instruction), but there are also division and square root instructions for vector normalization. Intel CPUs take many cycles for single-precision division and square root instructions,<sup>2</sup> although this has improved in the latest Penryn CPU family with its faster 4-bit divider.<sup>3</sup> Additionally, the limitations in register capacity lead to many MOV instructions in the x86 code (presumably to/from L1 cache). In contrast, the GeForce 8800 executes a reciprocal square-root thread instruction in four clocks; see Section B.6 for special function accuracy. It has a larger register file (per thread) and shared memory that can be accessed as an instruction operand. Finally, the CUDA compiler emits 15 instructions for one iteration of the loop, compared with more than 40 instructions from a variety of x86 CPU compilers. Greater parallelism, faster execution of complex instructions, more register space, and an efficient compiler all combine to explain the dramatic performance improvement of the N-body code between the CPU and the GPU.

---

<sup>2</sup> The x86 SSE instructions reciprocal-square-root (RSQRT\*) and reciprocal (RCP\*) were not considered, as their accuracy is too low to be comparable.

<sup>3</sup> Intel Corporation, *Intel 64 and IA-32 Architectures Optimization Reference Manual*. November 2007. Order Number: 248966-016. Also available at [www3.intel.com/design/processor/manuals/248966.pdf](http://www3.intel.com/design/processor/manuals/248966.pdf).

On a GeForce 8800, the all-pairs N-body algorithm delivers more than 240 GFLOPS of performance, compared to less than 2 GFLOPS on recent sequential processors. Compiling and executing the CUDA version of the code on a CPU demonstrates that the problem scales well to multicore CPUs, but is still significantly slower than a single GPU.

We coupled the GPU N-body simulation with a graphical display of the motion, and can interactively display 16K bodies interacting at 44 frames per second. This allows astrophysical and biophysical events to be displayed and navigated at interactive rates. Additionally, we can parameterize many settings, such as noise reduction, damping, and integration techniques, immediately displaying their effects on the dynamics of the system. This provides scientists with stunning visual imagery, boosting their insights on otherwise invisible systems (too large or small, too fast or too slow), allowing them to create better models of physical phenomena.

Figure B.8.17 shows a time-series display of an astrophysical simulation of 16K bodies, with each body acting as a galaxy. The initial configuration is a spherical shell

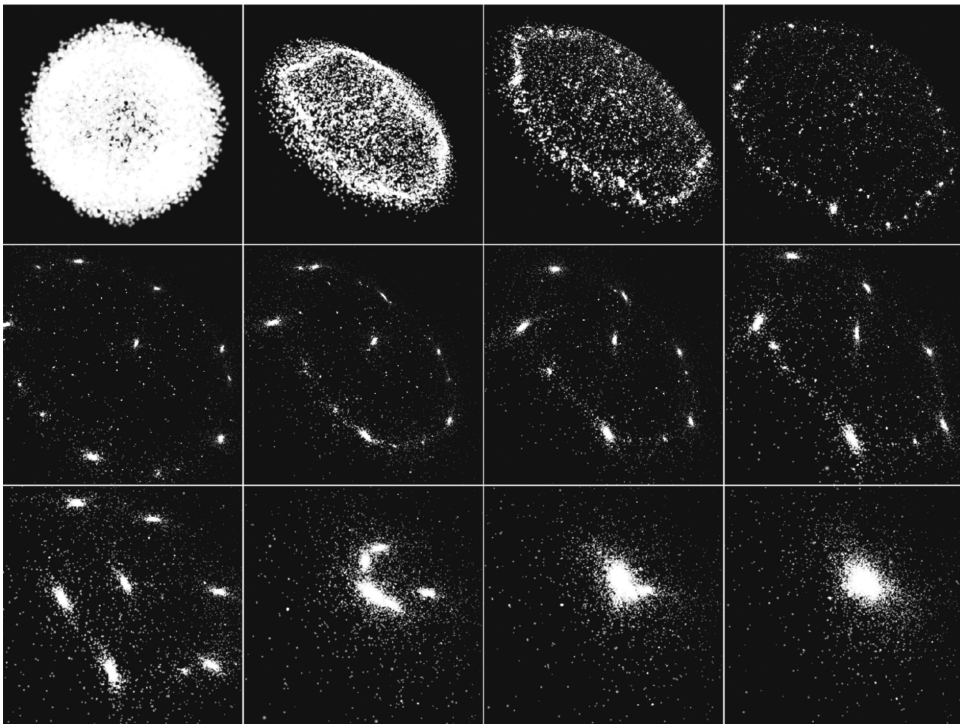

**FIGURE B.8.17** Twelve images captured during the evolution of an N-body system with 16,384 bodies.

of bodies rotating about the  $z$ -axis. One phenomenon of interest to astrophysicists is the clustering that occurs, along with the merging of galaxies over time. For the interested reader, the CUDA code for this application is available in the CUDA SDK from [www.nvidia.com/CUDA](http://www.nvidia.com/CUDA).

## B.9 Fallacies and Pitfalls

GPUs have evolved and changed so rapidly that many fallacies and pitfalls have arisen. We cover a few here.

*Fallacy: GPUs are just SIMD vector multiprocessors.*

It is easy to draw the false conclusion that GPUs are simply SIMD vector multiprocessors. GPUs do have a SPMD-style programming model, in that a programmer can write a single program that is executed in multiple thread instances with multiple data. The execution of these threads is not purely SIMD or vector, however; it is *single-instruction multiple-thread* (SIMT), described in Section B.4. Each GPU thread has its own scalar registers, thread private memory, thread execution state, thread ID, independent execution and branch path, and effective program counter, and can address memory independently. Although a group of threads (e.g., a warp of 32 threads) executes more efficiently when the PCs for the threads are the same, this is not necessary. So, the multiprocessors are not purely SIMD. The thread execution model is MIMD with barrier synchronization and SIMT optimizations. Execution is more efficient if individual thread load/store memory accesses can be coalesced into block accesses, as well. However, this is not strictly necessary. In a purely SIMD vector architecture, memory/register accesses for different threads must be aligned in a regular vector pattern. A GPU has no such restriction for register or memory accesses; however, execution is more efficient if warps of threads access local blocks of data.

In a further departure from a pure SIMD model, an SIMT GPU can execute more than one warp of threads concurrently. In graphics applications, there may be multiple groups of vertex programs, pixel programs, and geometry programs running in the multiprocessor array concurrently. Computing programs may also execute different programs concurrently in different warps.

*Fallacy: GPU performance cannot grow faster than Moore's law.*

Moore's law is simply a rate. It is not a "speed of light" limit for any other rate. Moore's law describes an expectation that, over time, as semiconductor technology advances and transistors become smaller, the manufacturing cost per transistor will decline exponentially. Put another way, given a constant manufacturing cost, the

number of transistors will increase exponentially. Gordon Moore [1965] predicted that this progression would provide roughly two times the number of transistors for the same manufacturing cost every year, and later revised it to doubling every 2 years. Although Moore made the initial prediction in 1965 when there were just 50 components per integrated circuit, it has proved remarkably consistent. The reduction of transistor size has historically had other benefits, such as lower power per transistor and faster clock speeds at constant power.

This increasing bounty of transistors is used by chip architects to build processors, memory, and other components. For some time, CPU designers have used the extra transistors to increase processor performance at a rate similar to Moore's law, so much so that many people think that processor performance growth of two times every 18–24 months is Moore's law. In fact, it is not.

Microprocessor designers spend some of the new transistors on processor cores, improving the architecture and design, and pipelining for more clock speed. The rest of the new transistors are used for providing more cache, to make memory access faster. In contrast, GPU designers use almost none of the new transistors to provide more cache; most of the transistors are used for improving the processor cores and adding more processor cores.

GPUs get faster by four mechanisms. First, GPU designers reap the Moore's law bounty directly by applying exponentially more transistors to building more parallel, and thus faster, processors. Second, GPU designers can improve on the architecture over time, increasing the efficiency of the processing. Third, Moore's law assumes constant cost, so the Moore's law rate can clearly be exceeded by spending more for larger chips with more transistors. Fourth, GPU memory systems have increased their effective bandwidth at a pace nearly comparable to the processing rate, by using faster memories, wider memories, data compression, and better caches. The combination of these four approaches has historically allowed GPU performance to double regularly, roughly every 12 to 18 months. This rate, exceeding the rate of Moore's law, has been demonstrated on graphics applications for approximately 10 years and shows no sign of significant slowdown. The most challenging rate limiter appears to be the memory system, but competitive innovation is advancing that rapidly too.

*Fallacy: GPUs only render 3D graphics; they can't do general computation.*

GPUs are built to render 3D graphics as well as 2D graphics and video. To meet the demands of graphics software developers as expressed in the interfaces and performance/feature requirements of the graphics APIs, GPUs have become massively parallel programmable floating-point processors. In the graphics domain, these processors are programmed through the graphics APIs and with arcane graphics programming languages (GLSL, Cg, and HLSL, in OpenGL and Direct3D). However, there is nothing preventing GPU architects from exposing

the parallel processor cores to programmers without the graphics API or the arcane graphics languages.

In fact, the Tesla architecture family of GPUs exposes the processors through a software environment known as CUDA, which allows programmers to develop general application programs using the C language and soon C++. GPUs are Turing-complete processors, so they can run any program that a CPU can run, although perhaps less well. And perhaps faster.

*Fallacy: GPUs cannot run double-precision floating-point programs fast.*

In the past, GPUs could not run double-precision floating-point programs at all, except through software emulation. And that's not very fast at all. GPUs have made the progression from indexed arithmetic representation (lookup tables for colors) to 8-bit integers per color component, to fixed-point arithmetic, to single-precision floating-point, and recently added double precision. Modern GPUs perform virtually all calculations in single-precision IEEE floating-point arithmetic, and are beginning to use double precision in addition.

For a small additional cost, a GPU can support double-precision floating-point as well as single-precision floating-point. Today, double-precision runs more slowly than the single-precision speed, about five to ten times slower. For incremental additional cost, double-precision performance can be increased relative to single precision in stages, as more applications demand it.

*Fallacy: GPUs don't do floating-point correctly.*

GPUs, at least in the Tesla architecture family of processors, perform single-precision floating-point processing at a level prescribed by the IEEE 754 floating-point standard. So, in terms of accuracy, GPUs are the equal of any other IEEE 754-compliant processors.

Today, GPUs do not implement some of the specific features described in the standard, such as handling denormalized numbers and providing precise floating-point exceptions. However, the recently introduced Tesla T10P GPU provides full IEEE rounding, fused-multiply-add, and denormalized number support for double precision.

*Pitfall: Just use more threads to cover longer memory latencies.*

CPU cores are typically designed to run a single thread at full speed. To run at full speed, every instruction and its data need to be available when it is time for that instruction to run. If the next instruction is not ready or the data required for that instruction is not available, the instruction cannot run and the processor stalls. External memory is distant from the processor, so it takes many cycles of wasted execution to fetch data from memory. Consequently, CPUs require large local

caches to keep running without stalling. Memory latency is long, so it is avoided by striving to run in the cache. At some point, program working set demands may be larger than any cache. Some CPUs have used multithreading to tolerate latency, but the number of threads per core has generally been limited to a small number.

The GPU strategy is different. GPU cores are designed to run many threads concurrently, but only one instruction from any thread at a time. Another way to say this is that a GPU runs each thread slowly, but in aggregate runs the threads efficiently. Each thread can tolerate some amount of memory latency, because other threads can run.

The downside of this is that multiple—many multiple threads—are required to cover the memory latency. In addition, if memory accesses are scattered or not correlated among threads, the memory system will get progressively slower in responding to each individual request. Eventually, even the multiple threads will not be able to cover the latency. So, the pitfall is that for the “just use more threads” strategy to work for covering latency, you have to have enough threads, and the threads have to be well-behaved in terms of locality of memory access.

*Fallacy:  $O(n)$  algorithms are difficult to speed up.*

No matter how fast the GPU is at processing data, the steps of transferring data to and from the device may limit the performance of algorithms with  $O(n)$  complexity (with a small amount of work per datum). The highest transfer rate over the PCIe bus is approximately 48 GB/second when DMA transfers are used, and slightly less for nonDMA transfers. The CPU, in contrast, has typical access speeds of 8–12 GB/second to system memory. Example problems, such as vector addition, will be limited by the transfer of the inputs to the GPU and the returning output from the computation.

There are three ways to overcome the cost of transferring data. First, try to leave the data on the GPU for as long as possible, instead of moving the data back and forth for different steps of a complicated algorithm. CUDA deliberately leaves data alone in the GPU between launches to support this.

Second, the GPU supports the concurrent operations of copy-in, copy-out and computation, so data can be streamed in and out of the device while it is computing. This model is useful for any data stream that can be processed as it arrives. Examples are video processing, network routing, data compression/decompression, and even simpler computations such as large vector mathematics.

The third suggestion is to use the CPU and GPU together, improving performance by assigning a subset of the work to each, treating the system as a heterogeneous computing platform. The CUDA programming model supports allocation of work to one or more GPUs along with continued use of the CPU without the use of threads (via asynchronous GPU functions), so it is relatively simple to keep all GPUs and a CPU working concurrently to solve problems even faster.



## B.10 Concluding Remarks

GPUs are massively parallel processors and have become widely used, not only for 3D graphics, but also for many other applications. This wide application was made possible by the evolution of graphics devices into programmable processors. The graphics application programming model for GPUs is usually an API such as DirectX™ or OpenGL™. For more general-purpose computing, the CUDA programming model uses an SPMD (*single-program multiple data*) style, executing a program with many parallel threads.

GPU parallelism will continue to scale with Moore's law, mainly by increasing the number of processors. Only the parallel programming models that can readily scale to hundreds of processor cores and thousands of threads will be successful in supporting manycore GPUs and CPUs. Also, only those applications that have many largely independent parallel tasks will be accelerated by massively parallel manycore architectures.

Parallel programming models for GPUs are becoming more flexible, for both graphics and parallel computing. For example, CUDA is evolving rapidly in the direction of full C/C++ functionality. Graphics APIs and programming models will likely adapt parallel computing capabilities and models from CUDA. Its SPMD-style threading model is scalable, and is a convenient, succinct, and easily learned model for expressing large amounts of parallelism.

Driven by these changes in the programming models, GPU architecture is in turn becoming more flexible and more programmable. GPU fixed-function units are becoming accessible from general programs, along the lines of how CUDA programs already use texture intrinsic functions to perform texture lookups using the GPU texture instruction and texture unit.

GPU architecture will continue to adapt to the usage patterns of both graphics and other application programmers. GPUs will continue to expand to include more processing power through additional processor cores, as well as increasing the thread and memory bandwidth available for programs. In addition, the programming models must evolve to include programming heterogeneous manycore systems including both GPUs and CPUs.

### Acknowledgments

This appendix is the work of several authors at NVIDIA. We gratefully acknowledge the significant contributions of Michael Garland, John Montrym, Doug Voorhies, Lars Nyland, Erik Lindholm, Paulius Micikevicius, Massimiliano Fatica, Stuart Oberman, and Vasily Volkov.

## B.11 Historical Perspective and Further Reading

### Graphics Pipeline Evolution

3D graphics pipeline hardware evolved from the large expensive systems of the early 1980s to small workstations and then to PC accelerators in the mid- to late-1990s. During this period, three major transitions occurred:

- Performance-leading graphics subsystems declined in price from \$50,000 to \$200.
- Performance increased from 50 million pixels per second to 1 billion pixels per second and from 100,000 vertices per second to 10 million vertices per second.
- Native hardware capabilities evolved from wireframe (polygon outlines) to flat shaded (constant color) filled polygons, to smooth shaded (interpolated color) filled polygons, to full-scene anti-aliasing with texture mapping and rudimentary multitexturing.

### Fixed-Function Graphics Pipelines

Throughout this period, graphics hardware was configurable, but not programmable by the application developer. With each generation, incremental improvements were offered. But developers were growing more sophisticated and asking for more new features than could be reasonably offered as built-in fixed functions. The NVIDIA GeForce 3, described by Lindholm et al. [2001], took the first step toward true general shader programmability. It exposed to the application developer what had been the private internal instruction set of the floating-point vertex engine. This coincided with the release of Microsoft's DirectX 8 and OpenGL's vertex shader extensions. Later GPUs, at the time of DirectX 9, extended general programmability and floating point capability to the pixel fragment stage, and made texture available at the vertex stage. The ATI Radeon 9700, introduced in 2002, featured a programmable 24-bit floating-point pixel fragment processor programmed with DirectX 9 and OpenGL. The GeForce FX added 32-bit floating-point pixel processors. This was part of a general trend toward unifying the functionality of the different stages, at least as far as the application programmer was concerned. NVIDIA's GeForce 6800 and 7800 series were built with separate processor designs and separate hardware dedicated to the vertex and to the fragment processing. The Xbox 360 introduced an early unified processor GPU in 2005, allowing vertex and pixel shaders to execute on the same processor.



## Evolution of Programmable Real-Time Graphics

During the last 30 years, graphics architecture has evolved from a simple pipeline for drawing wireframe diagrams to a highly parallel design consisting of several deep parallel pipelines capable of rendering complex interactive imagery that appears three-dimensional. Concurrently, many of the calculations involved became far more sophisticated and user-programmable.

In these graphics pipelines, certain stages do a great deal of floating-point arithmetic on completely independent data, such as transforming the position of triangle vertexes or generating pixel colors. This data independence is a key difference between GPUs and CPUs. A single frame, rendered in 1/60th of a second, might have 1 million triangles and 6 million pixels. The opportunity to use hardware parallelism to exploit this data independence is tremendous.

The specific functions executed at a few graphics pipeline stages vary with rendering algorithms and have evolved to be programmable. Vertex programs map the position of triangle vertices on to the screen, altering their position, color, or orientation. Typically a vertex shader thread inputs a floating-point  $(x, y, z, w)$  vertex position and computes a floating-point  $(x, y, z)$  screen position. Geometry programs operate on primitives defined by multiple vertices, changing them or generating additional primitives. Pixel fragment shaders each “shade” one pixel, computing a floating-point *red, green, blue, alpha* (RGBA) color contribution to the rendered image at its pixel sample  $(x, y)$  image position. For all three types of graphics shaders, program instances can be run in parallel, because each works on independent data, produces independent results, and has no side effects.

Between these programmable graphics pipeline stages are dozens of fixed-function stages which perform well-defined tasks far more efficiently than a programmable processor could and which would benefit far less from programmability. For example, between the geometry processing stage and the pixel processing stage is a “rasterizer,” a complex state machine that determines exactly which pixels (and portions thereof) lie within each geometric primitive’s boundaries. Together, the mix of programmable and fixed-function stages is engineered to balance extreme performance with user control over the rendering algorithms.

Common rendering algorithms perform a single pass over input primitives and access other memory resources in a highly coherent manner; these algorithms provide excellent bandwidth utilization and are largely insensitive to memory latency. Combined with a pixel shader workload that is usually compute-limited, these characteristics have guided GPUs along a different evolutionary path than CPUs. Whereas CPU die area is dominated by cache memory, GPUs are dominated by floating-point datapath and fixed-function logic. GPU memory interfaces emphasize bandwidth over latency (since latency can be readily hidden by a high thread count); indeed, bandwidth is typically many times higher than a CPU, exceeding 100 GB/second in some cases. The far-higher number of fine-grained lightweight threads effectively exploits the rich parallelism available.

Beginning with NVIDIA's GeForce 8800 GPU in 2006, the three programmable graphics stages are mapped to an array of unified processors; the logical graphics pipeline is physically a recirculating path that visits these processors three times, with much fixed-function graphics logic between visits. Since different rendering algorithms present wildly different loads among the three programmable stages, this unification provides processor load balancing.

## Unified Graphics and Computing Processors

By the DirectX 10 generation, the functionality of vertex and pixel fragment shaders was to be made identical to the programmer, and in fact a new logical stage was introduced, the geometry shader, to process all the vertices of a primitive rather than vertices in isolation. The GeForce 8800 was designed with DirectX 10 in mind. Developers were coming up with more sophisticated shading algorithms, and this motivated a sharp increase in the available shader operation rate, particularly floating-point operations. NVIDIA chose to pursue a processor design with higher operating frequency than standard-cell methodologies had allowed, to deliver the desired operation throughput as area-efficiently as possible. High-clock-speed design requires substantially more engineering effort, and this favored designing one processor, rather than two (or three, given the new geometry stage). It became worthwhile to take on the engineering challenges of a unified processor (load balancing and recirculation of a logical pipeline onto threads of the processor array) to get the benefits of one processor design.

## GPGPU: an Intermediate Step

As DirectX 9-capable GPUs became available, some researchers took notice of the raw performance growth path of GPUs and began to explore the use of GPUs to solve complex parallel problems. DirectX 9 GPUs had been designed only to match the features required by the graphics API. To access the computational resources, a programmer had to cast their problem into native graphics operations. For example, to run many simultaneous instances of a pixel shader, a triangle had to be issued to the GPU (with clipping to a rectangle shape if that's what was desired). Shaders did not have the means to perform arbitrary scatter operations to memory. The only way to write a result to memory was to emit it as a pixel color value, and configure the framebuffer operation stage to write (or blend, if desired) the result to a two-dimensional framebuffer. Furthermore, the only way to get a result from one pass of computation to the next was to write all parallel results to a pixel framebuffer, then use that framebuffer as a texture map as input to the pixel fragment shader of the next stage of the computation. Mapping general computations to a GPU in this era was quite awkward. Nevertheless, intrepid researchers demonstrated a handful of useful applications with painstaking efforts. This field was called "GPGPU" for general purpose computing on GPUs.

## GPU Computing

While developing the Tesla architecture for the GeForce 8800, NVIDIA realized its potential usefulness would be much greater if programmers could think of the GPU as a processor. NVIDIA selected a programming approach in which programmers would explicitly declare the data-parallel aspects of their workload.

For the DirectX 10 generation, NVIDIA had already begun work on a high-efficiency floating-point and integer processor that could run a variety of simultaneous workloads to support the logical graphics pipeline. This processor was designed to take advantage of the common case of groups of threads executing the same code path. NVIDIA added memory load and store instructions with integer byte addressing to support the requirements of compiled C programs. It introduced the thread block (cooperative thread array), grid of thread blocks, and barrier synchronization to dispatch and manage highly parallel computing work. Atomic memory operations were added. NVIDIA developed the CUDA C/C++ compiler, libraries, and runtime software to enable programmers to readily access the new data-parallel computation model and develop applications.

## Scalable GPUs

Scalability has been an attractive feature of graphics systems from the beginning. Workstation graphics systems gave customers a choice in pixel horsepower by varying the number of pixel processor circuit boards installed. Prior to the mid-1990s PC graphics scaling was almost nonexistent. There was one option—the VGA controller. As 3D-capable accelerators appeared, the market had room for a range of offerings. 3dfx introduced multiboard scaling with the original SLI (*Scan Line Interleave*) on their Voodoo2, which held the performance crown for its time (1998). Also in 1998, NVIDIA introduced distinct products as variants on a single architecture with Riva TNT Ultra (high-performance) and Vanta (low-cost), first by speed binning and packaging, then with separate chip designs (GeForce 2 GTS & GeForce 2 MX). At present, for a given architecture generation, four or five separate GPU chip designs are needed to cover the range of desktop PC performance and price points. In addition, there are separate segments in notebook and workstation systems. After acquiring 3dfx, NVIDIA continued the multi-GPU SLI concept in 2004, starting with GeForce 6800—providing multi-GPU scalability transparently to the programmer and to the user. Functional behavior is identical across the scaling range; one application will run unchanged on any implementation of an architectural family.

CPUs are scaling to higher transistor counts by increasing the number of constant-performance cores on a die, rather than increasing the performance of a single core. At this writing the industry is transitioning from dual-core to quad-core, with eight-core not far behind. Programmers are forced to find fourfold to eightfold task parallelism to fully utilize these processors, and applications using task parallelism must be rewritten frequently to target each successive doubling of

core count. In contrast, the highly multithreaded GPU encourages the use of many-fold data parallelism and thread parallelism, which readily scales to thousands of parallel threads on many processors. The GPU scalable parallel programming model for graphics and parallel computing is designed for transparent and portable scalability. A graphics program or CUDA program is written once and runs on a GPU with any number of processors. As shown in Section B.1, a CUDA programmer explicitly states both fine-grained and coarse-grained parallelism in a thread program by decomposing the problem into grids of thread blocks—the same program will run efficiently on GPUs or CPUs of any size in current and future generations as well.

## Recent Developments

Academic and industrial work on applications using CUDA has produced hundreds of examples of successful CUDA programs. Many of these programs run the application tens or hundreds of times faster than multicore CPUs are capable of running them. Examples include n-body simulation, molecular modeling, computational finance, and oil and gas exploration data processing. Although many of these use single-precision floating-point arithmetic, some problems require double precision. The recent arrival of double-precision floating-point in GPUs enables an even broader range of applications to benefit from GPU acceleration.

For a comprehensive list and examples of current developments in applications that are accelerated by GPUs, visit CUDAZone: [www.nvidia.com/CUDA](http://www.nvidia.com/CUDA).

## Future Trends

Naturally, the number of processor cores will continue to increase in proportion to increases in available transistors as silicon processes improve. In addition, GPUs will continue to enjoy vigorous architectural evolution. Despite their demonstrated high performance on data-parallel applications, GPU core processors are still of relatively simple design. More aggressive techniques will be introduced with each successive architecture to increase the actual utilization of the calculating units. Because scalable parallel computing on GPUs is a new field, novel applications are rapidly being created. By studying them, GPU designers will discover and implement new machine optimizations.

## Further Reading

Akeley, K. and T. Jermoluk [1988]. “High-Performance Polygon Rendering,” *Proc. SIGGRAPH 1988* (August), 239–46.

Akeley, K. [1993]. “RealityEngine Graphics.” *Proc. SIGGRAPH 1993* (August), 109–16.

Blelloch, G. B. [1990]. “Prefix Sums and Their Applications.” In John H. Reif (Ed.), *Synthesis of Parallel Algorithms*, Morgan Kaufmann Publishers, San Francisco.

Blythe, D. [2006]. “The Direct3D 10 System,” *ACM Trans. Graphics*, Vol. 25, no. 3 (July), 724–34.

- Buck, I., T. Foley, D. Horn, J. Sugerman, K. Fatahian, M. Houston, and P. Hanrahan [2004]. "Brook for GPUs: Stream Computing on Graphics Hardware." *Proc. SIGGRAPH 2004*, 777–86, August. <http://doi.acm.org/10.1145/1186562.1015800>.
- Elder, G. [2002]. "Radeon 9700." Eurographics/SIGGRAPH Workshop on Graphics Hardware, Hot3D Session, [www.graphicshardware.org/previous/www\\_2002/presentations/Hot3D-RADEON9700.ppt](http://www.graphicshardware.org/previous/www_2002/presentations/Hot3D-RADEON9700.ppt).
- Fernando, R. and M. J. Kilgard [2003]. *The Cg Tutorial: The Definitive Guide to Programmable Real-Time Graphics*, Addison-Wesley, Reading, MA.
- Fernando, R. ed. [2004]. *GPU Gems: Programming Techniques, Tips, and Tricks for Real-Time Graphics*, Addison-Wesley, Reading, MA. [https://developer.nvidia.com/gpugems/GPUGems/gpugems\\_pref01.html](https://developer.nvidia.com/gpugems/GPUGems/gpugems_pref01.html).
- Foley, J., A. van Dam, S. Feiner, and J. Hughes [1995]. *Computer Graphics: Principles and Practice, second edition in C*, Addison-Wesley, Reading, MA.
- Hillis, W. D. and G. L. Steele [1986]. "Data parallel algorithms." *Commun. ACM* 29, 12 (Dec.), 1170–83. <http://doi.acm.org/10.1145/7902.7903>.
- IEEE Std 754-2008 [2008]. *IEEE Standard for Floating-Point Arithmetic*. ISBN 978-0-7381-5752-8, STD95802, <http://ieeexplore.ieee.org/servlet/opac?punumber=4610933> (Aug. 29).
- Industrial Light and Magic [2003]. *OpenEXR*, [www.openexr.com](http://www.openexr.com).
- Intel Corporation [2007]. *Intel 64 and IA-32 Architectures Optimization Reference Manual*. November. Order Number: 248966-016. <http://www.intel.com/content/dam/www/public/us/en/documents/manuals/64-ia-32-architectures-optimization-manual.pdf>.
- Kessenich, J. [2006]. *The OpenGL Shading Language, Language Version 1.20, Sept. 2006*. [www.opengl.org/documentation/specs/](http://www.opengl.org/documentation/specs/).
- Kirk, D. and D. Voorhies [1990]. "The Rendering Architecture of the DN10000VS." *Proc. SIGGRAPH 1990* (August), 299–307.
- Lindholm E., M. J. Kilgard, and H. Moreton [2001]. "A User- Programmable Vertex Engine." *Proc. SIGGRAPH 2001* (August), 149–58.
- Lindholm E., J. Nickolls, S. Oberman, and J. Montrym [2008]. "NVIDIA Tesla: A Unified Graphics and Computing Architecture." *IEEE Micro*, Vol. 28, no. 2 (March–April), 39–55.
- Microsoft Corporation. Microsoft DirectX Specification, <https://msdn.microsoft.com/en-us/library/windows/apps/hh452744.aspx>.
- Microsoft Corporation. [2003]. *Microsoft DirectX 9 Programmable Graphics Pipeline*, Microsoft Press, Redmond, WA.
- Montrym, J., D. Baum, D. Dignam, and C. Migdal [1997]. "InfiniteReality: A Real-Time Graphics System." *Proc. SIGGRAPH 1997* (August), 293–301 .
- Montrym, J. and H. Moreton [2005]. "The GeForce 6800," *IEEE Micro*, Vol. 25, no. 2 (March–April), 41–51.
- Moore, G. E. [1965]. "Cramming more components onto integrated circuits," *Electronics*, Vol. 38, no. 8 (April 19).

- Nguyen, H., ed. [2008]. *GPU Gems 3*, Addison-Wesley, Reading, MA.
- Nickolls, J., I. Buck, M. Garland, and K. Skadron [2008]. "Scalable Parallel Programming with CUDA," *ACM Queue*, Vol. 6, no. 2 (March–April) 40–53.
- NVIDIA [2007]. CUDA Zone. [http://www.nvidia.com/object/cuda\\_home\\_new.html](http://www.nvidia.com/object/cuda_home_new.html).
- NVIDIA [2007]. *CUDA Programming Guide 1.1*. <https://developer.nvidia.com/nvidia-gpu-programming-guide>.
- NVIDIA [2007]. *PTX: Parallel Thread Execution ISA version 1.1*. [www.nvidia.com/object/io\\_1195170102263.html](http://www.nvidia.com/object/io_1195170102263.html).
- Nyland, L., M. Harris, and J. Prins [2007]. "Fast N-Body Simulation with CUDA." In *GPU Gems 3*, H. Nguyen (Ed.), Addison-Wesley, Reading, MA.
- Oberman, S. F. and M. Y. Siu [2005]. "A High-Performance Area-Efficient Multifunction Interpolator," *Proc. Seventeenth IEEE Symp. Computer Arithmetic*, 272–79.
- Patterson, D. A. and J. L. Hennessy [2004]. *Computer Organization and Design: The Hardware/Software Interface*, third edition, Morgan Kaufmann Publishers, San Francisco.
- Pharr, M. ed. [2005]. *GPU Gems 2: Programming Techniques for High-Performance Graphics and General-Purpose Computation*, Addison-Wesley, Reading, MA.
- Satish, N., M. Harris, and M. Garland [2008]. "Designing Efficient Sorting Algorithms for Manycore GPUs," NVIDIA Technical Report NVR-2008-001.
- Segal, M. and K. Akeley [2006]. *The OpenGL Graphics System: A Specification, Version 2.1, Dec. 1, 2006*. [www.opengl.org/documentation/specs/](http://www.opengl.org/documentation/specs/).
- Sengupta, S., M. Harris, Y. Zhang, and J. D. Owens [2007]. "Scan Primitives for GPU Computing." In *Proc. of Graphics Hardware 2007* (August), 97–106.
- Volkov, V. and J. Demmel [2008]. "LU, QR and Cholesky Factorizations using Vector Capabilities of GPUs," Technical Report No. UCB/EECS-2008-49, 1–11. <http://www.eecs.berkeley.edu/Pubs/TechRpts/2008/EECS-2008-49.pdf>.
- Williams, S., L. Oliker, R. Vuduc, J. Shalf, K. Yelick, and J. Demmel [2007]. "Optimization of sparse matrix-vector multiplication on emerging multicore platforms," In *Proc. Supercomputing 2007*, November.